

## 2007 IFWLA WOMEN'S LACROSSE RULES

### 1. FIELD MARKINGS (Diagram #1)

- A. The playing area shall be marked with a **solid lined rectangular boundary, 100m-122m long between end lines and 50m-60m wide between sidelines**. Four cones may be used to mark the corners of the field. All lines used in marking the field shall be 5.1cm wide. No unauthorized marks/lines may be added to the field. A playing area of 122m x 60m is desirable for IFWLA events. (Tournaments Rule 24)
- B. The playing area must be flat and free of stones, glass and protruding objects. The team bench sideline boundary **must** be 4m away from the Scorer's Table. (Rule 1.J) There must be 2m-4m of space between the opposite sideline and end line boundaries and any natural or artificial objects, such as trees, bushes, athletic tracks, spectators or stands, etc.
- C. A line called the Goal Line shall be marked at each end of the field. **The Goal Lines shall be no less than 82m and no greater than 92m apart**. The Goal Lines shall be 1.83m in length and shall be marked parallel to the end lines. (Rule 2)
- D. **There must be 9m-15m of playing space behind each Goal Line** running the full width of the field. The 9m-15m of playing space behind each Goal Line shall be measured from the back, outside edge of the Goal Line extended, to the front, inside edge of the end line.
- Two small visible marks shall be added to the field behind each goal, 4m in from the boundary and 11m from the centre of the Goal Line. These marks indicate the nearest spot to restart play when the playing space from the Goal Line to the end line boundary is less than the 15m maximum.
- E. Around each Goal Line a circle, called the Goal Circle, shall be marked. It shall have a radius of 3m measured from the centre, back edge of the Goal Line to the outside edge of the Goal Circle. (Diagram #4)
- F. Restraining Lines shall be marked at each end of the field, 27m up field from each Goal Line. These solid lines shall extend across the full width of the field. The 27m shall be measured from the back edge of the Goal Line to the front/midfield edge of the Restraining Line.
- G. In the centre of the field, a Centre Circle shall be marked and have a radius of 9m when measured from the centre of the circle to its outside edge. Through the centre of this circle, a centerline, 3m in length, shall be marked parallel to the Goal Lines.
- H. Directions for marking the 11m Area and the Marking Area. (Diagram #2)
- Locate D, a point on the centre, back edge of the Goal Line. Using point D as the centre, draw a circle with radius 3m measured from point D to the outside edge of the Goal Circle. Lightly mark lines AB and DB as shown.
  - Using point D as the centre, lightly draw a semicircle with radius 11m measured from point D to the outside edge of the semicircle. Mark point G (perpendicular to the centre of the Goal Line at D).
  - Connect A to B and extend this line to the 11m semicircle. Mark point C on each side as shown. (Lines BC are at a 45-degree angle to the Goal Line extended;  $\angle EBC = 45^\circ$ )
  - Draw a hash mark 31cm in length at point G. This hash mark shall be perpendicular to the centre of the Goal Line and bisected by the 11m semicircle at point G. Make three additional hash marks on the semicircle every 4m on each side of point G. There shall be seven hash marks total as shown.
  - At point H, 11m from the centre of the Goal Circle on the Goal Line extended, draw two additional 15cm marks that are perpendicular to the Goal Line extended. (These marks are not hash marks but indicate where the 11m semicircle would have intersected the Goal Line extended if the semicircle had been drawn as a solid line.) **This entire 11m semicircle is called the 11m Area.**
  - Mark the curve of the arc with a solid line from C to C. Mark each side of the arc with a solid line from B to C. **This smaller enclosed area is called the Marking Area.** The "pie" shaped area,  $\angle HBC$ , is referred to as "11m outside the Marking Area".
  - Measurements:  
A-G = 14.0m B-C = 8.65m D-H = 11.0m  
A-C = 12.85m D-G = 11.0m D-E = 15.0m  
A-B = 4.2m D-C = 11.0m  $\angle EBC = 45^\circ$

**1. FIELD MARKINGS** (continued)

I. 15m Fan:

Using point D as the centre, draw a semicircle with a solid line and radius 15m measured from D to the outside edge of the semicircle. **This entire semicircle, called the 15m Fan**, intersects the Goal Line extended at point E, as shown. The 15m Fan designates the maximum distance for calling Obstruction of the Free Space to Goal. (Rule 20.A.10). It also defines the part of the Advantage Flag Area above/in front of the goal line extended. (Rule 21.A & Rule 23 Definitions- Diagram #7)

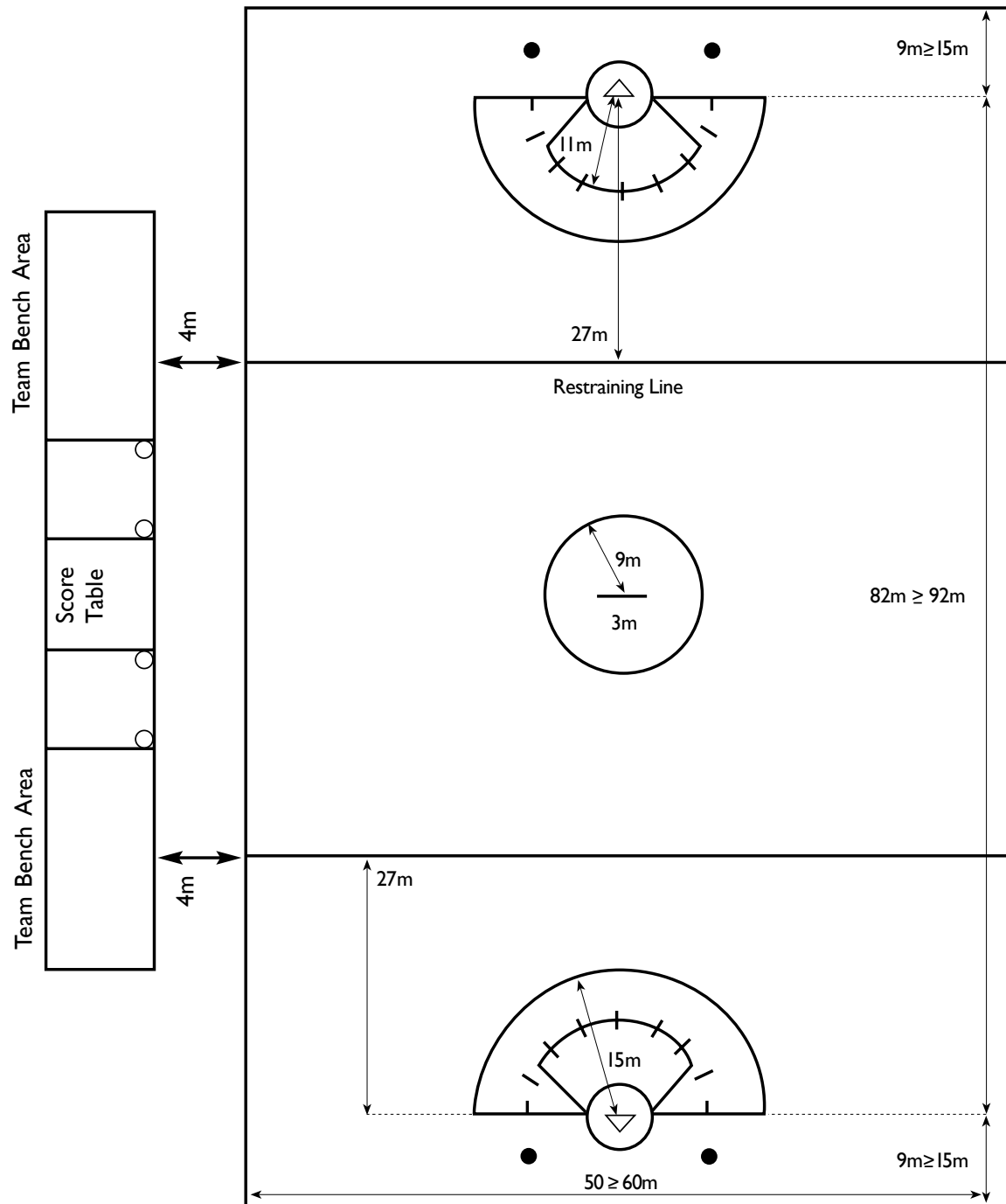

**Diagram #1**  
**Field Markings Rule 1**  
**A smaller field may be used for non-IFWLA events**  
**upon mutual agreement by the coaches / captains.**

1. FIELD MARKINGS (continued)

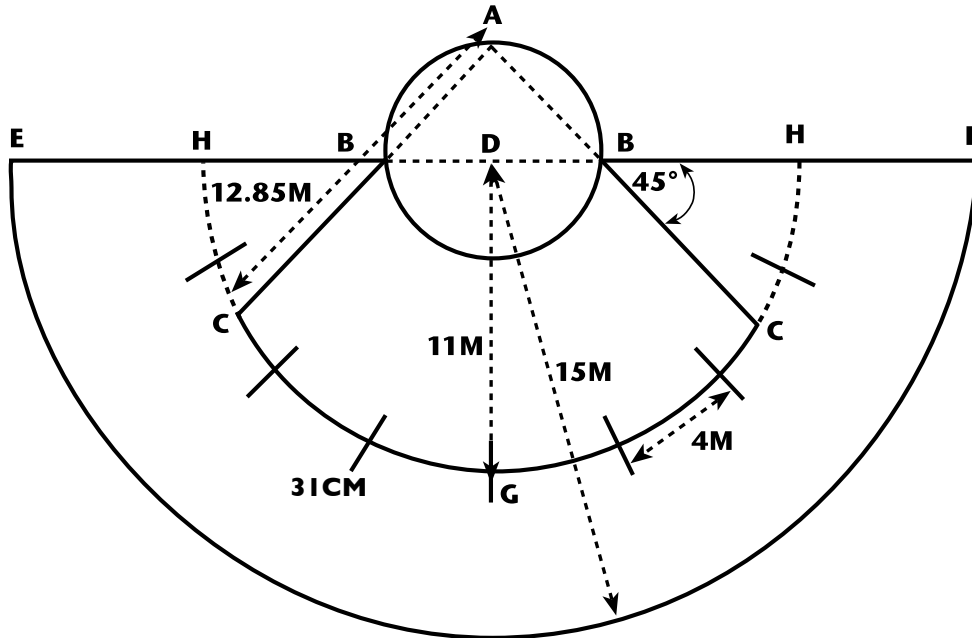
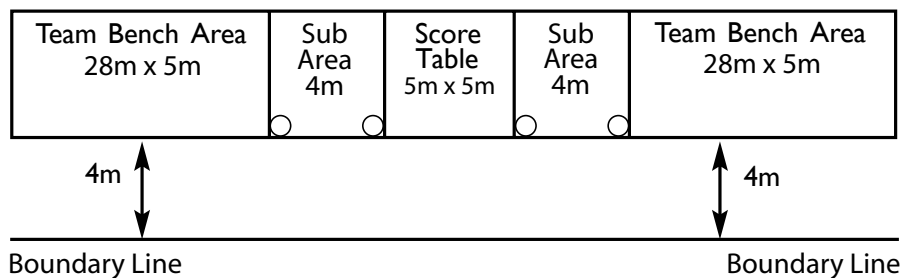

**Diagram #2**  
**Directions for marking the 11m Area and the**  
**Marking Area Directions for marking the 15m Fan**  
**Rule 1.H and 1.I**

- J. A Scorer's/Timer's Table shall be set at midfield in a marked 5m x 5m box that is 4m outside the boundary on the teams' bench side of the field.

Each Team's Substitution Area shall be 4m x 5m and defined by two cones/markers placed 4m apart and even with the Scorer's/Timer's table extended. Players must exit and enter the game through this gate area only. Players waiting to substitute must stand behind the markers and are the only Team/Bench Personnel permitted in the Substitution Area.

The Coach and other Team/Bench Personnel must remain outside the boundary, behind the level of the Score Table extended and inside the Team Bench Area. The Team Bench Area shall be 28m long and 5m deep. (Diagram #3 and Rule 11)

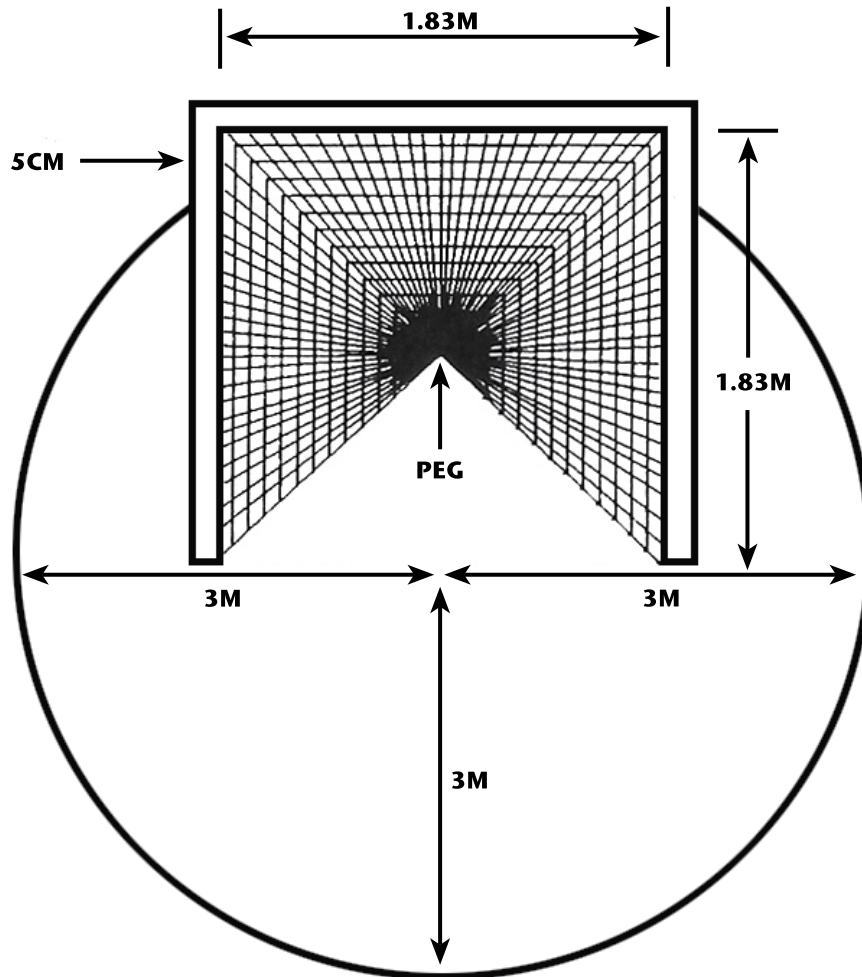

**Diagram #3**  
**Scorer's/Timer's Table, Substitution Area and Team Bench Area**  
**Rule 1.J**

**2. GOALS, GOAL POSTS, ETC.** (Diagram #4 and Manufacturer's Specifications, Rule 25.G)

A. A Goal shall be placed in each Goal Circle.

1. A Goal shall consist of two vertical posts/pipes joined at the top by a rigid crossbar. The posts/pipes shall be 1.83m apart and the top horizontal crossbar shall be 1.83m from the ground; all measurements are inside measurements. The Goal posts/pipes and crossbar shall be 5cm square or 5cm in diameter and must be silver or be painted white or orange.
  - a. If a freestanding Goal is used, all ground, side and centre back supports must be padded their **entire length** with material that limits the rebound of the ball. It is not necessary to pad Goals with flat or angled ground supports that prevent the ball from re-bouncing off the supports back into the playing area. (Diagram #5) No supporting braces should be placed in the corners of the goal that would prohibit a goal from being scored.
  - b. Any structure supporting the net behind the goal should allow the Goalkeeper to move freely in the back part of the goal Circle.
2. Mesh cotton or nylon goal netting must not be larger than 4cm. The Goal net must be securely attached to the posts/pipes, the crossbar and to a point on the ground 2.1m behind the centre of the Goal Line. The net should be strung so as to limit the rebound of the ball.
3. The Goal Line shall lie between the post/pipes and crossbar and be continuous with and the same width as the posts/pipes.



**Diagram #4**  
**Goal Circle, Goals and Goal Posts**  
**Rule 1.E. and Rule 2**

2. GOALS, GOAL POSTS, ETC. (continued)

SUPPORTS MUST BE PADDED

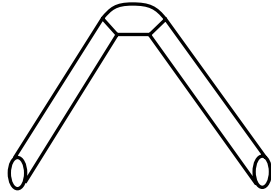

Rounded Pipes

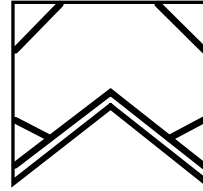

Darkened supports must be padded the entire length with material that limits the rebound of the ball.

SUPPORTS WHICH DO NOT REQUIRE PADDING

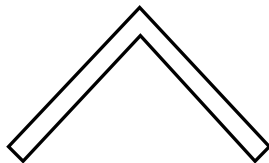

Flat Supports where the bottoms are flat metal, not pipes.

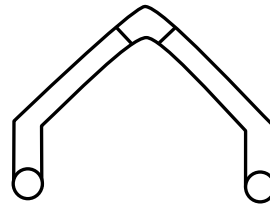

Angled Ground Pipes which prevent the ball from re-entering the playing area after hitting the ground.

**DIAGRAM #5**  
**Goal supports that must be padded**  
**Rule 2.A**

### 3. THE CROSSE

NOTE: The full Crosse specifications are printed in **Rule 25: Manufacturer's Specifications**. Only those aspects of the Crosse Rule that are necessary and useful for umpires, coaches and players during a game are printed below.

#### A. All Field Crosses

The primary intent of the Field Crosse specifications is to ensure that the ball moves freely within all parts of the head and pocket so that the ball may be dislodged from a Crosse without an excessively forceful check. A Crosse that has been altered in such a way as to give an unfair advantage to a player is illegal.

1. The head of the Field Crosse shall be constructed of wood, plastic, fiberglass, nylon, leather, rubber, gut, and/or any other synthetic material.
2. The head of a Field Crosse shall be triangular in concept. (Rule 25, Diagrams #12 & #13)
  - a. The inside width between the sidewalls of the head must continually increase from the center of the Bridge or Ball Stop to the widest point at the top of the head.
    - 1) The inside width between the walls of a wooden Crosse at the widest point at the top of the head shall be 15cm to 16cm.
    - 2) The inside width between the walls of a plastic / moulded head Crosse at the widest point at the top of the head shall be 16cm minimum.
  - b. There may be no protrusions or outcroppings on the inside surface of the sidewalls. The sidewalls may not be lined with any additional material.
3. The handle of the Field Crosse shall be straight and may be constructed of wood, metal alloy or other composite material. The Crosse shall not have sharp or protruding parts or edges and shall not be dangerous to players in any way.
  - a. Recessed metal screws with rounded heads shall be used to attach the head of a plastic molded head Crosse to the handle. The butt ends of all handles shall have an end cap, be taped or sanded smooth, if wood.
4. The overall length of the Field Crosse shall be 0.9m / 90cm minimum to 1.1m / 110 cm maximum. End caps are included when measuring the overall length of a Crosse.
5. The pockets of all Field Crosses shall be strung with 4 or 5 longitudinal leather or synthetic thongs and 8 to 12 stitches of cross lacing. MESH POCKETS ARE NOT ALLOWED.
  - a. Thongs must not touch, and 'nominally' must be evenly spaced along the length / across the width of the head. Loose ends of thongs may not be woven back up through the pocket of the Crosse and during play must be secured to the handle of the Crosse. (Rule 25, Diagram #12)
  - b. Cross-lacing in a traditionally strung pocket is defined as 8-12 knots/stitches, where two strings intertwine as a common place on a thong and evenly spaced (not bunched) diamonds. (A 'diamond' is the shape formed between two longitudinal knots on thongs and two horizontal knots).
  - c. Cross-lacing in a pre-manufactured detachable pocket is defined as 8-12 evenly spaced pocket nylon laces that are sewn or traditionally woven between evenly spaced longitudinal thongs. (Rule 3.A.5) Extra lengths of sidewall nylon ties must be cut to 4 cm maximum.
6. Field Crosses shall have no more than two separate shooting/throw strings. Shooting/throw strings shall not be rolled more than twice between each thong. Flat hockey or boot laces may not be used as shooting/throw strings.
  - a. Both shooting/throw strings must be attached in the upper third of the head, or
  - b. the top shooting/throw string must be attached in the upper third of the head, and the bottom shooting/throw string may be an "inverted U" in shape and must be attached in the upper one-half of the head, as measured from the top, outside edge of the scoop. (Rule 25, Diagram #16)
7. The Field Crosse meets specification if:
  - a. It complies with the criteria in Rule 3.A, and it meets the **Manufacturer's Specifications for Crosses in Rule 25**.
  - b. The top of the ball, when dropped into the pocket of a horizontally held Crosse, must **be seen and remain above** the top of the entire wooden or plastic sidewall wall after reasonable force with one hand has been applied to and released from a ball.
  - c. The ball must move freely within all parts of the head/pocket both laterally and along its full length. The ball must not become wedged between the walls, under the Guard or the Bridge of a Wooden Crosse or in the Ball Stop or under the walls of a Plastic/Moulded Head Crosse. The ball must easily fall out of the pocket of the Crosse when the Crosse is turned upside down.
8. At any time during play, an Umpire may take time-out to inspect a field Crosse, or any player on the field may request that an Umpire inspect an opponent's Crosse. If the ball becomes lodged in a field player's Crosse during play, the Crosse no longer meets specifications. The umpire shall take time-out to remove the illegal Crosse to the Scorer's/Timer's table. To resume play, the opponent nearest to the ball shall be awarded a Free Position for a Minor Foul. (Rule 19.A.12, Rule 19.A.13, and Rule 19.A.14)

### 3. THE CROSSE (continued)

#### B. Goalkeeper's Crosse

1. The Crosse shall be constructed of wood, plastic, fiberglass, nylon, leather, rubber, gut, and/or any other synthetic material.
2. The handle of the Crosse shall be straight and may be constructed of wood, metal alloy or other composite material.
  - a. Recessed metal screws with rounded heads must be used to attach the head to the handle. The butt end of the handle shall have an end cap, be taped or sanded smooth, if wood.
3. The Crosse shall not have sharp or protruding parts or edges and shall not be dangerous to players in any way.
4. The overall length of the Crosse shall be **.9m / 90cm minimum to 1.35m / 135cm maximum.**
5. The entire head of the Crosse shall be triangular in concept. The inside width between the sidewalls of the head must continually increase as measured from the centre of the Bridge or the Ball Stop to the widest point at the top of the head.
  - a. At the widest point of the head, the inside width between the walls of the head of the Crosse shall be 28.5cm to 30.5cm. The maximum outside width of the head shall be 33cm.
6. The pocket of the Crosse may be strung traditionally with 6 or 7 longitudinal leather or synthetic thongs and 8 to 12 stitches of cross-lacing or **MAY BE MESH.**
7. The Goalkeeper's Crosse may have more than two shooting/throw strings and flat hockey/boot laces may be used as shooting/throw strings. There are no restrictions regarding the design or placement of shooting/throw strings in the pocket of the Crosse.
8. The Crosse (strung head and handle) shall not weigh more than 773g
9. The Goalkeeper's Crosse meets specifications if:
  - a. It complies with the criteria in Rule 3.B. and it meets the **Manufacturer's Specifications for Crosses in Rule 25.E.**
  - b. The ball moves freely within all parts of the head/pocket both laterally and along its full length.
  - c. When the Crosse with the ball in it is held at eye level with the long axis of the stick vertical to the ground, more than one-half of the ball is seen above the Ball Stop.

### 4. THE BALL (Manufacturer's Specifications, Rule 25.F)

- A. The ball shall be solid rubber and may be any solid colour. For IFWLA tournaments, the colour of the ball must be solid yellow. (Tournament Rule 24)
  1. The circumference of the ball shall not be less than 20cm minimum or more than 20.3cm maximum.
  2. The ball shall weigh not less than 142g or more than 149g. It must have a bounce of not less than 1.1m and not more than 1.3m when dropped from 1.8m onto concrete at a temperature of approximately 18°C to 23° C.

## 5. TEAMS (Diagram #6)

- A. A game is played between two teams. **For IFWLA events, a roster of eighteen (18) players constitutes a full team; the remaining 6 are substitutes.** Any numbers of players up to twelve (12) are permitted on the field at the same time. One of the twelve players on each team may be a Goalkeeper. If a team chooses to play without a Goalkeeper, an unprotected field player/Deputy may only enter the Goal Circle in accordance to Rule 17.A.4 and must **never** enter the Goal Circle to defend a shot.

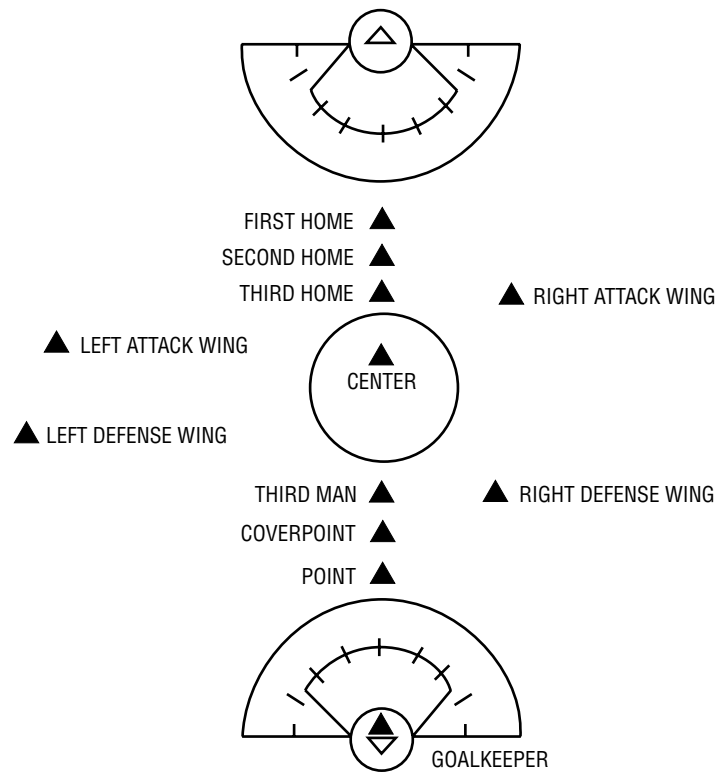

**Diagram #6**  
**Teams**  
**Rule 5**

## 6. PLAYER'S UNIFORM AND EQUIPMENT

- A. All team members shall be dressed uniformly, with the exception of the Goalkeeper. The Goalkeeper's top/shirt must be the same colour as her team's top/shirt. The bottom of her uniform must match or be in agreement with the predominant colour of her team's uniform kilt or shorts.
- B. Each player's uniform shirt shall be numbered identically on the front and back. Each team member shall have a different number and the colour of the numbers must clearly contrast the colour of the shirts. If a team wears a patterned shirt, the numbers must be superimposed on a solid, clearly contrasting colour block background.
1. Numbers must be a **solid block font**. Numbers on the centre front of the shirt must be at least **15cm tall**, and numbers on the centre back of the shirt must be at least **20cm tall**. **(To be phased in by the 2009 World Cup)**
  2. For IFWLA Tournaments, **numbers 1-40** only are permitted on team shirts. (Tournament Rule 24)
- C. All visible garments worn under the kilt or shorts must be the same predominant colour as the kilt or shorts. All visible undergarments worn under the uniform shirt must be the same predominant colour as the uniform shirt. All players wearing visible undergarments must be dressed in the same solid colour. This ruling does not apply to medical sleeves, e.g., padding under knee braces.
- D. Players may wear shoes with plastic, metal, leather or rubber cleats/studs. Spikes are not permitted. Regardless of their composition, the exposed surface of all studs/cleats must be smooth.

## 6. PLAYER'S UNIFORM AND EQUIPMENT (continued)

- E. All players, including the Goalkeeper, must properly wear a professionally manufactured intra-oral mouth guard. Mouth guards must not be altered to decrease protection. Close-fitting gloves, nose guards, and eye guards may be worn. Field players are not permitted to wear headgear or face masks. Additional protective devices warranted on genuine medical necessity shall be evaluated before the game and may be worn providing the Coaches/Captains and the Umpires agree that such equipment is not dangerous to other players. All protective devices must be close fitting and padded where necessary and must not be of excessive weight.
- F. The Goalkeeper must wear a helmet with facemask, a throat protector and a chest or body pad. She may also wear padded gloves, arm pads and leg pads. All padding must fit securely and must not increase the width of the Goalkeeper's body beyond the thickness of the padding. The maximum thickness of the padding is 3cm. Padded gloves must be tied securely at the cuff and must not have any webbing.
- G. Players must remove earrings, necklaces, bracelets, watches and any other visible body piercing. Medical jewellery with information visible, soft jewellery and rings must be taped securely to the player or be removed. Flat barrettes or hair slides are legal. The Umpire may rule any body or hair decoration as dangerous to the player herself or to others, remove it from the field of play, and if applicable, penalize the player for a Minor Foul.
- H. No equipment, including protective devices may be used unless it complies with the rules and is deemed safe by the Umpires and Coaches/Captains. See Rules 19.A.11 and Rule 19.A.12 for penalties when a player's uniform and/or equipment is illegal.

## 7. CAPTAINS

Each team shall designate one speaking Captain for the game. The designated Captain **may** choose to wear a distinctive armband. The Captain's number shall be noted on the official Team Score Sheet.

- A. The Captain shall:
  - 1. meet with the charge Umpire to call the coin toss for choice of end to defend. The visiting team's Captain shall call all coin tosses.
  - 2. meet with the Umpires to agree on the length of playing time and halftime intermission.
  - 3. meet with the Umpires, to agree about the safety and use of protective equipment, warranted on genuine medical necessity, that will be used during the game.
  - 4. indicate that her team is ready to play at the beginning of each half.
  - 5. indicate a substitute for an injured player or suspended player.
  - 6. confer with the Umpires if weather conditions or any other extenuating circumstances make the continuation of the game questionable. (Rule 10.F)
  - 7. while on the field, be permitted to request a Team Time-out directly to an Umpire, after a goal has been scored. (Rule 10.H)
  - 8. approach the Umpires for clarification of rules during a Team Time-out, at halftime and immediately following the game. (Rule 8.A.11)

## 8. THE UMPIRES

The Umpires shall enforce the rules in accordance with the procedures and guidelines set forth by the IFWLA. The Umpires are solely responsible for judging safe and fair play.

- A. The Umpires shall:
  - 1. be in charge of the game 30 minutes prior to the start of the game. The Umpire in charge of the game shall be on the Scorer's Table side of the field (2 Umpires) or shall begin the game at the centre position (3 Umpires).
  - 2. prior to the game, inspect the grounds, goals, the ball, Crosses, clothing, boots/shoes, jewellery and protective equipment to ensure they comply with the rules.
  - 3. agree with the Captains/Coaches about the safety of protective equipment warranted on genuine medical necessity.
  - 4. ensure the Timer and Scorer understand their responsibilities. (Rule 9)
  - 5. determine which Umpire will be in charge of the game. The Charge Umpire will conduct the coin toss with the Captains.
  - 6. agree with the Captains/Coaches on the length of playing time and halftime. (Rule 10.A)

## 8. THE UMPIRES (continued)

7. Officiate the game in accordance with the IFWLA rules.
8. officiate in the same field position both halves of the game when two Umpires are working the game. Three Umpires may rotate their field positions clockwise following every goal or every two goals.
9. report goals and player warnings or suspensions to the Scorer.
10. confer with the Captains and/or Coach if weather conditions or any other extenuating circumstances make the continuation of the game questionable. If a game must be interrupted or suspended, the Umpire's decision is final. (Rule 10.F)
11. be available to clarify rules for the Captains during a Team Time-out, and for Captains and Coaches, during halftime and immediately following the Game.
12. make the game official by signing the Team Score Sheet.
13. wear a black and white vertical stripe (2.5cm) shirt and/or jacket, a black kilt, appropriate length black shorts or black long pants. Black or white visors/hats, black or white short socks or long black socks may be worn. All other garments and accessories must be black. It is recommended Umpires be similarly attired.

### **THE UMPIRES' DECISIONS ARE FINAL AND WITHOUT APPEAL.**

## 9. SCORERS AND TIMERS

### A. The Scorer shall:

1. Record the rosters (names and shirt numbers) of both teams on the Team Score Sheet prior to the game.
2. Keep an accurate record of the goals scored and Team Time-outs.
3. record all warning and suspension cards. Record the time on the game clock when a player is suspended, and at what time on the game clock the player or her substitute may re-enter the game.
4. immediately inform the nearest Umpire when there has been an illegal substitution. An extra player, an ineligible suspended player or an illegal player (one incorrectly or not listed on the Team Score Sheet) are all illegal substitutes. (Rule 11.A)

### B. The Timer shall:

1. prior to the game, confirm with the Umpires the length of each half and overtime, when played.
2. at each Draw, start the clock on the Umpire's whistle. If a Draw must be repeated, the clock continues to run.
3. stop the clock at the Umpire's whistle and goal signal following each goal for the entire game.
  - a. Exception: Based upon mutual agreement prior to each event or game, the clock shall continue to run after goals if one team is leading by 12 or more goals. (Rule 10.D and Tournament Rule 24)
4. during the last two minutes of each half, stop the clock on every stoppage of play. When play is stopped (the ball is "dead") prior to the last two minutes, the timer shall stop the clock when it reaches two minutes if play has not resumed. The clock shall be restarted at the Umpire's whistle.
5. notify the Umpire when there are 2 minutes remaining in each half and display a Yellow Flag at the Scorer's Table.
6. notify the Umpire when there are 30 seconds remaining in each half and replace the Yellow Flag at the Scorer's Table with a Red Flag.
7. verbally count down to the nearest Umpire the last 10 seconds of each half and sound the horn when time is expired.
8. Notify the Umpires when 2 minutes remain during halftime intermission.
9. time the recovery time allowed for an incapacitated player. A field player is allowed up to 2 minutes and the Goalkeeper is allowed up to 5 minutes recovery time. (Rules 11.C and 12.D)
10. Time the lapsed playing time suspension penalties of:
  - a. 2 minutes before a player who receives a Personal Yellow Card may return to the game. A substitute may enter immediately unless the Yellow card is the team's third. (Rule 11.B.1 & Rule 22.B.4)
  - b. 5 minutes before a substitute may enter the game for a suspended player following a Personal Yellow/Red Card. (Rule 11.B.2 & Rule 22.B.5)
  - c. 10 minutes before a substitute may enter the game for a suspended player following a straight Personal Red Card. (Rule 11.B.2 & Rule 22.B.5)
  - d. 5 minutes before the player or her substitute may enter the game following a Green/Red Card for a Delay of Game or other Persistent Minor Foul. (Rule 22.D.3)
11. Time the 90-second Team Time-out when requested following a Goal. (Rule 10.H)

## 10. DURATION OF PLAY

- A. The duration of the game shall be 60 minutes maximum, two 30-minute periods/halves.
- B. The horn indicates the end of time in each half and overtime period. After halftime, which may not exceed 10 minutes, the teams shall change ends. (Rule 10.I)
- C. The Umpire's whistle starts and stops play. When the whistle sounds to stop play, all players, except for the Goalkeeper within the Goal Circle, must 'stand' and may not move until the whistle sounds again to resume play. (Rule 16)

The game begins at the sound of the Umpire's whistle at the opening Draw. The game is restarted with a Draw after a goal is scored, following halftime intermission, and following Team Time-outs. In some instances the game begins with a Throw or a Free Position. (Rule 12, Rule 15, Rule 19.A.20 and Rule 21.D.5)

- D. The clock is stopped on the Umpire's whistle and goal signal when a goal is scored, and at every whistle that stops play during the last 2 minutes of each half. When play is stopped (the ball is "dead") prior to the last two minutes, the Timer shall stop the clock when it reaches two minutes if play has not resumed.

Additionally, the clock is stopped to issue Personal Misconduct and Delay of Game or other Persistent Minor Foul warning cards and suspensions, for Team Time-outs, and to remove an illegal player / substitute.

- 1. Event Coordinators, Coaches, Captains and Umpires may mutually agree not to stop the clock after goals if one team is ahead by 12 or more goals. If the goal difference becomes less than 12 goals, the stop clock shall be reinstated. Even if there is a 12-goal difference, the clock shall always stop on every whistle that stops play within the last 2 minutes of each half. (Tournament Rule 24)
- E. Play shall be continuous, but at the discretion of the Umpire, a Time-out may be taken for unusual circumstances. (Rule 12.D)
- F. If weather conditions or any other extenuating circumstances make play dangerous, the Umpires shall suspend the game after consultation with the Captains/Coaches. The Umpires' decision is final.
- G. A game is considered legal and complete if 80% of the playing time has elapsed. Eighty percent of a 60-minute game is 48 minutes. If an interrupted game (one in which less than 80% of the game has been played) is continued on the same day, it shall be restarted from the point of interruption. A suspended game that is replayed on another day must be replayed from the beginning.
- H. Each Team may request two 90-second Team Time-outs per game, after a Goal has been scored. A coach may request the Time-out through the Scorer's Table, or the Captain on the field may make the request directly to the nearest Umpire. Only one team will be granted a Team Time-out after a goal. Team Time-outs not used during regulation game time, are permitted during overtime. (Tournament Rule 24)
- I. It is recommended that a horn be used to end each half and Team Time-out. When a horn is not available, the Umpire's whistle (three short blasts) will indicate the end of each half.

## 11. SUBSTITUTION

- A. Each team may substitute an unlimited number of players at any time during play (including overtime), after every goal, after a Team Time-out and at halftime. All substitutions must take place through the Team's Substitution Area. All players, including the Goalkeeper, must come off the field and exit between the cones/markers before their substitute may go onto the field. No other players (or coaches) are permitted in the Team Substitution Areas except those players waiting to imminently enter the game.
  - 1. An extra player, an ineligible suspended player or an illegal player are illegal substitutes. (Rule 9.A.4 & Rule 19.A.15)
  - 2. Once the game starts, a player whose name and number are listed incorrectly on or have been omitted from the Team Score Sheet may enter the game when the correction is made. Their team shall be penalized for illegal substitution. (Rule 22.B.5)
- B. Substitution may be made for a suspended player, but a suspended player may NEVER re-enter the game unless she has been removed for a Yellow Card Personal/Misconduct offense or has received a Green/Red Card for a Delay of Game or other persistent Minor Foul offense. No other players may substitute when a card is administered. (Rule 22.B and Rule 22.D)

## 11. SUBSTITUTION (continued)

1. For a personal Yellow Card, there must be a 2-minute lapse of playing time before the player may re-enter the game. A substitute may take her place unless the yellow card is her Team's third. The time allowed for substitution following the administration of a Yellow Card shall not exceed 30 seconds. (Rule 22.B)
    - a. If the Yellow Card is a team's third, the team must play with one less player below/goal side of the Restraining Lines for the time lapsed 2-minute penalty.
    - b. If a team's **'only dressed'** Goalkeeper is awarded her team's third Yellow Card, she may remain in the game. If the team has a **'second dressed'** Goalkeeper, she will replace the carded Goalkeeper. To resume play, the Goalkeeper will move 4m behind the player awarded the Free Position, and the teammate who is below/goal side of the restraining line and nearest to her team's substitution area must leave the field to begin the 2-minute penalty suspension. (See Rule 22.B.4)
    - c. For Yellow/Red and Straight Red Cards the time lapsed 5 or 10- minute penalty will override the 2-minute penalty.
  2. For a personal Yellow/Red or straight Red Card, there must be a 5-minute lapse of playing time for a Yellow/Red Card, and a 10-minute lapse of playing time for a straight Red Card, before a substitute may enter the game.
    - a. If a Goalkeeper is suspended from further participation in the game, and her team has a **'second dressed'** Goalkeeper, the field player below /goal side of the restraining line and nearest to the substitution box must leave the field to begin the 5 or 10-minute suspension. To resume play, the **'second dressed'** Goalkeeper shall stand 4m behind the attack player awarded the Free Position. The Goal Circle shall remain empty.
    - b. If a Goalkeeper is suspended from further participation in the game, and she is her team's **'only dressed'** Goalkeeper, a 2-minute time-out shall be taken to enable the nominated player to put on protective equipment. If this player is on the field a substitute will take her place. The teammate below/goal side of the restraining line and nearest to the substitution box must leave the field to begin the 5 or 10-minute suspension. To resume play, the "newly dressed" Goalkeeper must stand 4m behind the attack player awarded the Free Position. The Goal Circle shall remain empty.
  3. For a Green/Red Card, there must be a 5-minute lapse of playing time before the suspended player or a substitute may enter the game. (Rule 22.D) See Rule 11.B.2. & Rule 22.B.5. for procedures to replace a Goalkeeper if she receives a Green/Red card.
  4. When the time of the suspension has expired, an eligible player or substitute must return to the field through the Team Substitution Area only.
    - a. If a player is suspended with less than 2 minutes (Yellow Card), 5 minutes (Yellow/Red Card), or 10 minutes (straight Red Card) remaining in the half, the suspension will carry over into the second half or overtime, if played.
    - b. If an eligible player or substitute enters the game before the time of the suspension expires, the player or her team must re-serve the entire time of suspension.
- C. Time-out is not taken for substitution except in the event of illness, accident or injury. An incapacitated Field Player is allowed up to 2-minutes recovery time, and an incapacitated Goalkeeper is allowed up to 5-minutes recovery time. (Rule 12.D)

No player is allowed to remain on the field with an open wound or blood-saturated clothing or equipment. (Appendix A: IFWLA Blood Policy)

1. When a substitution is made during an injury time-out, no other substitutions are permitted. The substitute must assume the same location as the injured player she is replacing; no advantage shall be gained. There may be no exchange of positions on the field during an injury substitution until play resumes unless the injury substitution occurs after a Goal or if the injured player is her team's **'only dressed'** Goalkeeper.
  - a. If the Goalkeeper's substitute is a player on the field, she will be permitted to leave the game to put on protective equipment and replace the injured Goalkeeper. A player from the bench may replace the field player.
2. Following an injury Time-out the game shall be restarted in accordance with Rule 12.D.

## 12. TO START AND RESTART THE GAME

To start the game, and to restart the game after halftime or after a goal is scored, a Draw is taken at the centerline. A Draw is also taken to start each overtime period. In some instances a Throw or a Free Position may be taken to restart play.

- A. To Draw, two opponents stand with one foot **"Toeing the Centreline"**. Their Crosses are held in the air above hip level, wood/plastic to wood/plastic, parallel to and above the centreline. The Crosses shall be held back to back, the right sidewall facing downward, so that each player's Crosse is between the ball and the Goal she is defending. (Definitions, Rule 23)

## 12. TO START AND RESTART THE GAME (continued)

- B. The Umpire places the ball between the Crosses. Once the Crosses are set, the Umpire says, "Ready" before moving backwards out of the Centre Circle. At the word "Ready", players taking the Draw must not move or draw until the Umpire blows the whistle. At the whistle, both players must immediately draw their Crosses up and away from one another. The flight of the ball must go higher than the heads of both players taking the Draw.
1. When a player draws illegally, the opponent shall be awarded a Minor Foul Free Position at the centreline. (Rule 19.A.8.)
  2. If both players draw illegally or it cannot be determined why the Draw was illegal, a Throw shall be taken. (Rule 15.B.8 and Rule 19.A.8)
- C. During the draw, the players outside the Centre Circle are not required to 'stand' but their feet must remain completely outside the Centre Circle until the whistle. Players may hang their Crosses into the Centre Circle, but their Crosses may not touch the ground inside the Circle. The Goalkeepers must remain below/goal side of their respective defensive Restraining Lines. (Rule 19.A.16)
- D. If the game must be stopped because of an accident, injury, illness, interference, inadvertent whistle or any other circumstance related or unrelated to the ball, the game will be restarted in one of three ways.
1. If a foul occurred, a Free Position shall be awarded at a spot determined by the Umpire in accordance with the conditions set forth in Rules 19, 20, or 21. Play shall not resume within 11m of the centre of the Goal Line or within 4m of the boundary.
  2. If a foul did not occur, the ball shall be awarded to the player who was in possession of it when play was stopped. Play shall not resume within 11m of the of the center of the Goal Line or within 4m of the boundary, and the ball carrier must be given at least 1m of clear/free space.
  3. If neither team had possession of the ball when play was stopped, a Throw shall be awarded at or near the incident and/or the spot of the ball when play was stopped; at least 15m from the centre of the Goal Line, 4m inside the boundary and 4m away from the Restraining Lines. (Rule 11.C, Rule 15.B.4 and Rule 15.B.5)

## 13. SCORING

- A. The Team scoring the greater number of Goals wins. If the scores are equal, the result is a tie. When a winner must be determined, overtime procedures are in Rule 24.
- B. A goal is scored when the whole ball passes completely over the whole Goal Line, between the goal posts and under the crossbar from in front, having been propelled from an attack player's legal Crosse or from the Crosse or off of the body of a defender.
- C. A Goal is **NOT** scored when:
1. the ball is put through the Goal by a non-player, including an umpire. (Rule 15.B.1)
  2. the ball comes off the person/body of an attack player.
  3. the ball enters the Goal any time after a whistle is blown or the horn is sounded.
  4. the attack shooter steps on or over the Goal Circle Line or any other attack player is illegally in the Goal Circle. (Rule 17.A.1)
  5. while within the Goal Circle, the Goalkeeper or her Crosse are interfered with in any way by an attack player. (Rule 17.B.1)
  6. the Umpire rules that a pass, shot or follow-through is dangerous. (Rule 20.A.7, Rule 20.A.8 and Rule 20.A.9)
  7. the ball enters the Goal while the attacking team has an illegal player on the field. (Rule 11, Rule 18.B.6, Rule 19.A.15 and Rule 22)
  8. the ball enters the Goal from an attack player's illegal Crosse. (Rule 19.A.12)
  9. the player who shot the Goal adjusts her Crosse after an Umpire's request for a Crosse inspection. (Rule 19.A.13)
  10. the ball is put into the Goal by the Goalkeeper of the attacking team (Rule 19.A.17)
  11. the ball enters the Goal when the attacking team has more than eight players below the Restraining Line. (Rule 18.B.1)

## 14. BALL OUT-OF-BOUNDS

- A. When the ball goes out-of-bounds, the Umpire shall blow the whistle to stop play and players must 'stand'. Except in the case of a shot or deflected shot on goal, when a player in possession of the ball carries, propels, or when a player is the last to touch a loose ball before it goes out of bounds, the opponents will be awarded the ball when play resumes. Players may not take an active part in the game when their foot/feet are out of bounds. During the game players may not run out of bounds and re-enter to a more advantageous position.
1. With the exceptions below in Rule 14.B.3, Rule 14.C.1, and Rule 14.C.2, an out-of bounds call is a simple change of possession, not a foul.
- B. When a player is in possession of the ball and steps on or over the boundary line, or any part of her body or Crosse touches the ground on or outside the boundary line, the ball is out-of-bounds; and the player shall lose possession of it.
1. A player is **in possession** of the ball when the ball is in her Crosse, and she can perform any of the normal functions of control such as cradling, carrying, passing or shooting the ball. (Definitions, Rule 23)
  2. A player in possession of the ball may hold her Crosse outside the boundary as long as her foot/feet do not touch the boundary line and still be considered in bounds. If an opponent, whose feet are in bounds, legally checks the player's Crosse and causes the ball to fall to the ground out-of-bounds, possession will be awarded to the opponent when play resumes.
  3. When an opponent illegally causes a player in possession of the ball to go out-of-bounds, the ball carrier shall maintain possession of the ball when play resumes. The opponent shall be penalized for the foul.
- C. When a loose ball touches the boundary line or the ground outside the boundary line, the ball is out-of-bounds. The player/team that last touched the ball before it went out-of-bounds shall lose possession of it, unless it was a shot or a deflected shot on Goal.
1. If a player deliberately pushes, flicks or bats the ball into an opponent's feet or body to win possession of the ball at the boundary, the opponents shall be awarded a Major Foul Free Position 4m inside the boundary. Repeated violations may be carded. (Rule 20.A.19)
  2. It is a Minor Foul when a player uses her foot/feet or any other part of her body to stop the ball from going out-of-bounds. (Rule 19.A.4)
- D. To resume play when the ball has gone out-of-bounds,
1. The opponent nearest the ball (including the Goalkeeper even if she is in the goal circle) will place the ball in her Crosse and stand 4m inside the boundary from the spot where the ball went out of bounds.
  2. Any other player(s) directly involved in the play or in the immediate vicinity of the spot where the ball went out of bounds may also be moved. Players must maintain the same relative field position and relationship to the player with the ball as they had when the whistle sounded to stop play.
  3. Opponents must give the player awarded the ball at least 1m of free space (stick and feet), and may not reposition themselves unless they are directed to move by the umpire.
  4. All other players must stand. Play resumes at the whistle.
- E. When a shot or deflected shot on goal goes out of bounds, the player nearest to the ball when it crosses the boundary (including the goalkeeper even if she is within her goal circle) will place the ball in her Crosse and stand 4m inside the boundary line from the spot where the ball went out of bounds. Play may not resume within 11m from the center of the goal line within 4m of the boundary. (Rule 14.D)
1. A **deflected shot** is one that goes directly out of bounds after hitting the goal post or the Goalkeeper's Crosse or body. A deflection occurs when a player merely touches the ball with her Crosse or body and does not gain any distinct/clear advantage or control of the ball.
  2. A shot or deflected shot remains a shot until the ball goes out of bounds, the ball comes to rest on the field of play, a player gains possession of the ball, or a player otherwise causes the ball to go out of bounds.
  3. When a shot or deflected shot goes out-of-bounds off an umpire's body, a Throw will be awarded to resume. (Rules 15.B.3)
  4. It is the umpire's responsibility to determine if a thrown ball is a shot, and the umpire will immediately call out the word "shot".
- F. When the ball goes directly out-of-bounds from a legal Draw, a Throw shall be awarded 4m inside the boundary, 4m away from the Restraining Line, and at least 15m from the centre of the Goal Line. (Rule 15.B.9)
- G. When the ball goes out-of-bounds over an end line boundary, play shall not resume within 4m of the end line or 11m of the centre of the Goal Line.

## 15. THROW

- A. Two opposing players stand with their feet and Crosses at least 1m apart. Each player stands nearer the Goal she is defending and faces in toward the playing area. The Umpire stands between 6m to 8m from the players and simultaneously blows the whistle and tosses the ball in a short high arc towards the players so they can catch or otherwise play the ball as they move in toward the game.

A Throw is administered at or near the incident and/or the spot of the ball when play was stopped, except that, all throws must be taken at least 15m from the centre of the Goal Line, 4m inside the boundary and 4m away from the Restraining Lines. Whenever, the attack team fouls (Major or Minor) during an Advantage Flag, a Throw shall be taken beyond 15m, level with the Goal Line extension. (Rule 21.D.5)

No other player may be within 4m of the two players taking the Throw. If the Throw is inaccurate or is not touched by either player, it must be repeated.

- B. A Throw is taken when:
1. the ball goes into the Goal off of a non-player, including an umpire. The two nearest opponents shall be awarded a Throw on the Goal Line extension at least 15m from the centre of the Goal Line. (Rule 13.C.1)
  2. the ball goes out-of-bounds following a shot, and two opponents are equidistant (stick or feet) from the ball where it crosses the boundary.
  3. following a shot, the ball deflects out-of-bounds off an umpire's body. (Rule 14.E.3)
  4. there is an incident unrelated to the ball, neither team has possession of the ball. (Rule 12.D)
  5. the game is restarted after an incident related to the ball, neither team has committed a foul, and neither team has possession of the ball. (Rule 12.D)
  6. the ball lodges in the clothing of a field player or Umpire.
  7. two opponents foul simultaneously (Major/Major or Minor/Minor). (Rule 16.B.5)
  8. both Centres draw illegally or it cannot be determined why the Draw was illegal. (Rules 12.B and 19.A.8)
  9. the ball goes directly out-of-bounds from a Draw. The Throw shall be awarded 4m inside the boundary from where it went out-of-bounds. (Rule 14.F)
  10. the attacking team fouls (Major/Minor) during a raised Advantage Flag. (Rule 21.D.6)

## 16. CONDUCT OF PLAY

- A. The ball is "dead" whenever the Umpire blows the whistle to stop play. All players, except the Goalkeeper or her Deputy while within the Goal Circle, must '**stand**' and may not move until play resumes or unless they are directed to do so by the Umpire. When the game is restarted, the player with the ball may run, pass or shoot.
- B. Violation of any rule is a foul. The penalty for a foul is a Free Position. A Free Position must not be taken within 11m of the centre of the Goal Line or within 4m of the boundary.
1. The Umpire indicates where the player taking the Free Position shall stand.
  2. No other player's body or Crosse is allowed within 4m of the player awarded the Free Position. Any player who is within this distance must move away to a position indicated by the Umpire.
  3. The player who committed the foul shall move 4m from the player taking the Free Position, except for the Goalkeeper when she commits a Goal Circle Foul or when she commits a Minor Foul while she is completely or partially within her Goal Circle. (Rules 17.C and 19.B.2)
    - a. For Minor Foul penalties, the player who committed the foul will stand 4m away in the direction from which she approached her opponent before committing the foul. (Rule 19: Minor Fouls and Penalties)
    - b. For Major Foul penalties, the player who committed the foul, including the Goalkeeper, will stand 4m directly behind the player taking the Free Position (Rule 20: Major Fouls and Penalties)
  4. To resume play, the player taking the Free Position places the ball in her Crosse, and at the Umpire's whistle, the player may run, shoot or pass.
  5. If two opposing players foul simultaneously and the fouls are equivalent (Minor/Minor or Major/Major), a Throw is taken. (Rule 15.F) If the fouls are not equivalent (Major/Minor), the team committing the Major Foul is penalized. (Exception: Rule 21.D.6: Advantage Flag.)

### C. HELD WHISTLE

An Umpire may refrain from enforcing any rule when it would penalize the non-offending team. When a player is fouled but is able to maintain QUALITY possession of the ball, the Umpire will indicate that she has seen the foul by extending her arm in the direction the player is attacking.

## 17. GOAL CIRCLE RULES, FOULS AND PENALTIES

### A. Goal Circle Rules

1. Only one player, either the Goalkeeper or her **Deputy**, an unprotected field player, is allowed to be inside the Goal Circle at any one time. A ball resting on the Goal Circle line belongs to the Goalkeeper or her Deputy. (Definitions, Rule 23)
2. With the following exceptions, no other players are allowed to enter or have their feet, body or Crosse on or over the Goal Circle line at any time.
  - a. On a shot, the attack shooter may follow through with her Crosse over the Goal Circle Line, but her feet must not touch or cross over the Goal Circle Line. The shooting motion must be initiated from outside the Goal Circle; therefore, the shooter's Crosse must be outside the Goal Circle when she receives a pass from a teammate to attempt or complete a shot.
  - b. On a shot, only the defender/s directly marking the attack shooter may reach into the Goal Circle with their Crosse/s to block the shot or check the shooter's Crosse. The defender/s feet must not touch or cross over the Goal Circle Line.
3. The Goalkeeper while within the Goal Circle
  - a. must move the ball out of the Goal Circle within 10 seconds after the ball has entered the Goal Circle. (Rule 17.A.5)
  - b. may stop the ball with her hand, body and/or Crosse. If she catches the ball with her hand, she must put it in her Crosse and proceed with the game.
  - c. must remove a ball lodged in the goal netting, her clothing or pads, place it in her Crosse and proceed with the game.
  - d. may reach outside the Goal Circle with her Crosse and bring the ball back into the Goal Circle provided no part of her body is **Grounded** outside the Goal Circle. (Definitions, Rule 23)
4. The Deputy
  - a. may enter or remain in the Goal Circle only when her team has possession of the ball.
  - b. must immediately leave the Goal Circle when her team loses possession of the ball. A player/team is deemed to be NOT in possession of a loose ball (on the ground or in the air) when it is outside the Goal Circle.
  - c. may enter the Goal Circle to play a rolling or bouncing ball. However, a Deputy may NEVER enter the Goal Circle to defend any shot, including a bounce shot.
  - d. must move the ball out of the Goal Circle within 10 seconds after the ball has entered the Goal Circle. (Rule 17.A.5)
  - e. while within the Goal Circle, must remove a ball lodged in her clothing, her Crosse or the goal netting, place it in her Crosse and proceed with the game.
5. Once a Goalkeeper or her Deputy moves the ball out of the Goal Circle within 10 seconds, the ball cannot return to their team's Goal Circle until the ball has been **played**. **Played** refers to an action whereby the ball leaves the player's Crosse and is touched by another player, or her Crosse is checked Crosse to Crosse by an opposing player. (Definitions, Rule 23)
  - a. If she passes the ball from inside the Goal Circle to another player, the ball has been **played**.
  - b. If she moves out of the Goal Circle with the ball in her possession, she may not return the ball to her Goal Circle until it has been **played**.
  - c. If she gains possession of the ball outside the Goal Circle, she may return the ball to the Goal Circle for one 10-second count.
6. When the Goalkeeper or a Deputy is completely (both feet) outside the Goal Circle.
  - a. she loses all of her Goal Circle privileges.
  - b. she may only reenter the Goal Circle without the ball.
  - c. she may propel the ball into the Goal Circle and then follow it in.
  - d. she must return to the Goal Circle to play the ball that is inside the Goal Circle.

### B. Goal Circle Fouls

1. Field Players
  - a. On a shot, the attack shooter and the defender/s immediately marking the shooter must not step on/over the Goal Circle Line. (Rule 17.A.1)
  - b. The shooter must not receive a pass with her Crosse inside the Goal Circle.
  - c. During and immediately following the shot, the shooter must not illegally interfere with the Goalkeeper or the defenders immediately marking her. Defenders must not illegally interfere with the shooter. (Rule 20.A)
  - d. No other field players are allowed to enter or have their feet, body or Crosse on or over the Goal Circle line at any time.
  - e. A Deputy may not enter or remain in the Goal Circle illegally. (Rule 17.C.1.b)

## 17. GOAL CIRCLE RULES, FOULS AND PENALTIES (continued)

2. The Goalkeeper and her Deputy must not:
  - a. allow the ball to remain within the Goal Circle for longer than 10 seconds. Once the Goalkeeper or a Deputy moves the ball out of the goal circle, their team must not return the ball to their goal circle until it has been played. (Rule 17.A.5)
  - b. when inside the Goal Circle, reach outside the Goal Circle to play an aerial or ground ball with any part of her body. (Rule 19.A.4. and Rule 20.A.15)
  - c. draw the ball into her Goal Circle when any part of her body is completely grounded outside the Goal Circle, or in so doing, prevent an opponent from legally playing the ball.
  - d. throw any of her equipment to another player.
  - e. when outside the Goal Circle, step on the Goal Circle Line or into the Goal Circle with the ball in her Crosse.
- C. Penalties for Goal Circle Fouls
  1. With the two exceptions below, when the defence commits a Goal Circle Foul, the Free Position is taken 15m from the centre of the Goal Circle to the side of the Goal nearest the violation and level with the Goal Line extended. The offending player (unless it is the Goalkeeper) shall move to the 11m mark on the Goal Line extended.
    - a. Whenever the Goalkeeper commits a Goal Circle Foul, she remains on the spot of the foul, or if she was within or partially within the Goal Circle, she remains inside the Goal Circle.
    - b. When the Deputy is illegally in the Goal Circle, it is a Major Foul and play must be stopped immediately. The Free Position shall be awarded to the attack player who is nearest the centre 11m hash mark when play stops. The illegal Deputy will move 4m behind the attack player with the ball, and the Marking Area will be cleared. The Goalkeeper may NOT return to the Goal Circle until play resumes at the whistle.
  2. When the attack commits a Goal Circle foul, the Goalkeeper or a Deputy shall take the Free Position inside the Goal Circle. If a Goal was scored, the Goal shall not count. Before play resumes, all other players must move at least 4m away from the Goal Circle.
  3. Major Fouls that occur during or immediately following a shot, must be penalized in accordance with the conditions in Rule 20.B., Rule 22.A and Rule 22.B

## 18. RESTRAINING LINE RULES, FOULS AND PENALTIES

- A. A team must not:
  1. have more than eight attack players below/goal side of the Restraining Line in their offensive /attacking end of the field.
  2. have more than nine defence players below/goal side of the Restraining Line in their defensive end of the field. One of these nine players is usually, but not necessarily the Goalkeeper.
  3. Players may exchange places during play, but a player must have both feet above/behind the Restraining Line before a teammate can move below/goal side of the Restraining Line. An illegal exchange is an immediate whistle.
  4. Any part of a player's foot on or over the Restraining Line is a violation. Players may reach over the line with their sticks to play the ball as long as their feet are not on or over the line.
  5. The Restraining Line rule remains in effect at all times, for the entire game.
  6. Violation of the Restraining Line is a Minor Foul and is either an immediate call or a Held Whistle
- B. Penalties
  1. When the attack is offside:
    - a. if a Goal is scored, the Goal shall not Count. (Rule 13.C.11)
    - b. unless there are already 4 defenders (new attack) above/behind the restraining line, the closest defender below/goal side of the Restraining Line shall be awarded a Free Position just above/behind the centre of the Restraining Line. The attack player who was offside, or the attack player closest to the center of and below/goal side of the Restraining Line, shall move 4m to the side of the player with the ball relative to her field position when play was stopped.
    - c. and play ends with a Minor Foul by the defence, the attack will move back onside and a Throw will be administered at or near the spot of the ball when play stopped; at least 15m from the centre of the Goal Line, 4m from the boundary and 4m from the Restraining Line. (Rule 15.B.7)
  2. When the defence is offside:
    - a. If the ball is within the 15m Fan or anywhere within the Goal Circle when the violation is called, the attack shall be awarded a Free Position at the top centre of the 15m Fan.
      - 1) The attack player in possession of the ball when play is stopped, or the attack player nearest to the top centre of the 15m Fan shall be awarded the Free Position. The closest defender shall move 4m to the side of the player who is awarded the ball relative to her field position when play was stopped. The offside defender or the defender nearest to the Restraining Line shall move back onside.

## 18. RESTRAINING LINE RULES, FOULS AND PENALTIES (continued)

- b. If the ball is outside the 15m Fan or below the Goal Line extended when the offside violation is called, an attack Free Position shall be awarded at the spot of the ball; at least 11m from the centre of the Goal Line and 4m inside the boundary.
    - 1) The closest defender will move 4m to the side of the player with the ball relative to her field position when play was stopped. The offside defender or the defender nearest the Restraining Line shall move back onside.
  - c. and the defence commits an additional Minor Foul that causes play to be stopped, the defensive offside will be penalized.
  - d. Whenever the defence is penalized for an offside violation, and the Goalkeeper is outside the Goal Circle and has not fouled, the Goalkeeper may return to the Goal Circle for the Free Position.
3. When both the attack and defence are offside:
    - a. both players shall move back onside, and the Umpire shall award a Throw at or near the spot of the ball when play was stopped; at least 15m from the centre of the Goal Line, 4m from the Restraining Line and 4m inside the boundary.
  4. When play ends with a Major Foul by either the defence or the attack, correct the offside and penalize the Major Foul. Exception: Major and Minor fouls committed by the attack are offsetting during an Advantage Flag. (Rule 21.D.6)
  5. Whenever play ends with an out-of-bounds call (no foul) and a player is offside, penalize the Minor Foul offside.
  6. When play is stopped because an illegal player is both on the field and offside, remove the illegal player and penalize her team for the illegal offside.
  7. Repeated Restraining Line violations may be penalized as Major Fouls and carded. (Rule 22.B)

## 19. MINOR FOULS AND PENALTIES

### A. Minor Foul Rules

1. During the Draw, and at all times during a game, players must hold their Crosse on the shaft/handle only. The throat of the head is not considered part of the shaft.
2. A player must not cover a ground ball with her Crosse or any part of her body.
3. A player must not guard her Crosse with her arm.
4. A player must not touch the ball with her hand, use her hand or body to keep the ball in the Crosse or allow any part of her body to change the speed or direction of the ball to her team's **distinct/clear advantage**, except as in Rule 17.A.3.
5. A player must not check/tackle an opponent's empty Crosse while the opponent is trying to gain possession of the ball.
6. A player must not throw her Crosse under any circumstances.
7. A player must not take part in the game if she is not holding her own Crosse.
8. A player must not draw illegally. (Rule 12.B.) An illegal Draw occurs when
  - a. a centre moves after the Umpire says, "Ready", or draws before the Umpire's whistle.
  - b. a player makes no attempt to draw.
  - c. the movement of the Crosse is not up and away in any direction from the starting point.
  - d. the ball fails to go higher than the heads of both players taking the Draw.
    - 1) When a player draws illegally, the opponent shall be awarded a Free Position at the Centreline. The offending player shall move 4m away from her opponent toward the Goal she is defending and at a 45-degree angle to the Centreline.
    - 2) If both players draw illegally, or it cannot be determined why the Draw was illegal, a Throw shall be taken. For a Throw, the two centres remain at the Centreline each nearer the Goal she is defending.
9. During the Draw, a player must not enter the Centre Circle before the Umpire's whistle. (Rule 12.C)
10. A player must not intentionally delay the game (Rule 22.C & Rule 22.D)
11. A player must not take part in a game if her uniform is illegal. (Rule 6)
  - a. If any part of the uniform is illegal, including illegal jewellery or the absence of mouth guard, time-out shall be called and the player must leave the field to correct the violation before reentering the game through the Team Substitution Area when play resumes.
  - b. A Free Position shall be awarded to the opponent nearest to the ball. If the violation is discovered immediately after a Goal is scored, the Goal shall count and the Free Position shall be awarded at the Centreline.
12. A player must not play with illegal equipment. At an umpire's discretion, an umpire may take Time-out at any time during the game to re-inspect any equipment. Any player on the field may request an umpire to check the pocket of an opponent's Crosse. The player requesting the stick check must provide the Umpire with the shirt number of the opponent whose Crosse shall be checked. (Rule 3.A.8)

## 19. MINOR FOULS AND PENALTIES (continued)

- a. If the equipment is legal, the game shall be restarted by awarding the ball to the player who was in possession of it when time out was called. If neither team had possession of the ball, a throw shall be awarded to the two opponents who are nearest the spot of the ball.
  - b. If the equipment is illegal, it shall be placed at the Scorer's Table for the remainder of the half. The opponent nearest the spot of the ball shall be awarded a Free Position. The player may continue to play with equipment that is legal.
  - c. If a Goal is scored with an illegal Crosse, and the illegal Crosse is discovered before the game is restarted with a Draw, the Goal shall not count. All players must "Stand", and the opposing Goalkeeper shall be awarded a Free Position within her Goal Circle.
  - d. If any player other than the shooter is found to have an illegal Crosse after a Goal is scored and before the game is restarted with a Draw, the Goal shall count. The game will resume with a Free Position for the opponents at the Centreline.
13. A player must not adjust the thongs of her Crosse after an Umpire requests to inspect her Crosse.
  14. A team must not request, for a second time during a game, the inspection of a Crosse that meets rule specifications.
  15. A player must not substitute illegally. Illegal substitutes and/or illegal players include extra players on the field during the game or any suspended player who is ineligible to reenter the game. (Rule 11 and Rule 22)
    - a. The Umpire shall call time-out and remove the illegal player. The Free Position shall be awarded to the opponent in possession of or closest to the ball when play was stopped.
    - b. If an illegal player is discovered on the attacking team after a Goal is scored, but before the next Draw, the Goal shall not count. The illegal player shall be removed, and the opposing Goalkeeper shall be awarded a Free Position within her Goal Circle. Exception: If the illegal player is also offside, the Minor offside foul shall be penalized when play resumes. (Rule 18.B.6.)
  16. During the Draw, Goalkeepers must remain below/goal side of their team's defensive Restraining Line. At all other times during the game, the Goalkeeper must remain above/behind her team's offensive Restraining Line.
    - a. When a Goalkeeper is penalized for being above/behind her team's defensive Restraining Line during the Draw, she shall return to a legal position just below/goal side of the Restraining Line. The opponents shall be awarded a Free Position at or near the spot of the ball.
    - b. Whenever a Goalkeeper is below/goal side of her team's offensive Restraining Line, the opponents shall be awarded a Free Position just above/behind the center of the Restraining Line. The Goalkeeper shall move 4m to the side of the player taking the Free Position.
  17. The Goalkeeper must not score a goal for her own team.
    - a. For the Free Position, the offending Goalkeeper shall stand or move back to the Centreline, and the opposing Goalkeeper shall be awarded possession of the ball within her Goal Circle.
  18. A player must not hold the Crosse of an opponent for a short time during a check/tackle.
  19. Players must not false start / move their feet before an Umpire's whistle.
  20. A Team must promptly return to the field following, halftime, Team Time-outs or to the centre Draw following a Goal.
    - a. The Free Position shall be awarded at the Centreline. A player from the offending team shall move 4m away to either side of the player awarded the ball and at a 45-degree angle to the Centreline towards the Goal she is defending.
- B. Minor Foul Free Positions:
1. For Minor Fouls that occur **outside the 15m Fan or below the level of the Goal Line extension**, award the Free Position where the foul occurred. The offending player shall move 4m away from the player taking the Free Position in the direction from which she approached her opponent before committing the foul. This applies to the Goalkeeper if she commits a Minor Foul while she is completely (both feet) outside the Goal Circle. No Free Position shall ever be taken within 11m of the centre of the Goal Line except by the Goalkeeper or her Deputy, who may be awarded a Free Position inside the Goal Circle. (Rule 17.C.2)
  2. When the **defence commits a Minor Foul within the 15m Fan** (no Advantage Flag / Scoring Play), the attack player who was fouled shall be awarded a Free Position at a 'spot nearest the foul' on the 15m Fan. The player who fouled shall move 4m away from the player taking the Free Position, relative to her position at the time of the foul.
    - a. When the Goalkeeper commits a Minor Foul and she is partially or completely within the Goal Circle, she remains in her Goal Circle for the Free Position. No other defence player is required to move to within 4m of the Free Position.
    - b. Whenever the Goalkeeper is completely (both feet) outside her Goal Circle and commits a Minor foul she shall be penalized as a Field Player. (Rule 17.A.6)

## 19. MINOR FOULS AND PENALTIES (continued)

3. When the **attack commits a Minor Foul inside the 15 Fan (no Advantage Flag/Scoring Play)**, a Free Position shall be taken by the defence at the 'spot nearest the foul but no closer than 11m from the centre of the Goal Line. The player who fouled shall move 4m away, relative to her position at the time of the foul.
4. When the **attack commits a Minor Foul during an Advantage Flag**, a Throw shall be awarded. (Rule 21.C.4 and 21.D.6)
5. Delay of Game or other repeated/persistent Minor Fouls may be penalized as Major Fouls and may be carded. (Rule 22.F.)

## 20. MAJOR FOUL RULES & PENALTIES

### A. Major Foul Rules

1. A player must not roughly or recklessly check/tackle an opponent's Crosse.
2. A player must not strike an opponent with her Crosse or force an opponent's Crosse into the opponent's body. A Yellow Card **MUST** be given for a check that makes contact with a player's head.
3. A player must not hold her Crosse within a field Crosse width of an opponent's head or neck (approximately 18cm or the width of a player's shoulders).
4. A player must not reach around or across her opponent's body to check her opponent's Crosse when her feet are behind the opponent or level with the opponent.
5. A player in possession of the ball must not hold her Crosse near her own face or body, or near a teammate's face or body, with or without cradling, thereby making a legal check impossible.
6. A player must not charge, block, barge, shoulder, push with the hand, back into an opponent or force their way through a legal double team. A player may not move into the path of an opponent without giving the opponent sufficient time and/or space to stop or change direction. (Rule 20.A.2 Guidance)

When a player is running to receive the ball, a defensive player who is outside the opponent's **Visual Field** must give the opponent enough time and/or space to change direction. (Definitions, Rule 23)

7. A player must not propel the ball into an opponent. A Yellow Card **MUST** be given for Dangerous Propelling.
8. A player must not, at any time, follow-through with her Crosse in a dangerous or uncontrolled manner. A Yellow Card **MUST** be given for a Dangerous Follow-through.
9. A player must not shoot dangerously or without control. A Dangerous Shot is usually directed at the Goalkeeper. A Dangerous Shot is judged on any combination of the shooter's **distance** from the Goal, the **force** of the shot, and the **placement** of the shot.

A shot that does not give the Goalkeeper time to react may not be directed at her body, especially her head or neck. This does not apply when the Goalkeeper moves into the path of the shot or misplays the ball off her stick. A shot may be judged dangerous and/or uncontrolled even if it misses the Goal.

- a. The Goalkeeper will take the Free Position for all Dangerous Shots from inside the Goal Circle. The offending player shall move 4m directly behind the Goal Circle.
10. A defence player must not block the Goal outside the Goal Circle with any part of her body for the purpose of guarding, blockading or obstructing the **Free Space to the Goal**. Obstructing the Free Space to Goal denies the attacking team the chance to shoot safely. (Definitions, Rule 23, Diagram #9) This rule is in effect only when the attacking team is in possession of the ball within the 15m Fan.
  - a. Obstruction of the Free Space to Goal occurs when a defender is illegally in the Free Space at her own initiation.
  - b. A defender is **not** obstructing the Free Space if she is drawn into and through the Free Space to Goal by an attack player whom she is legally marking **within a stick's length**, approximately 1.5m. (Definitions, Rule 23)
  - c. Blocking the Free Space to Goal requires an immediate whistle in order to prevent injury. The Free Position shall be set relative to the spot of the ball. Rule 20.B.5)
11. A defender must not remain in the Marking Area in front of the Goal Circle for more than three seconds unless she is marking an opponent 'within a stick's length'. To be exempt from the 3-Seconds Rule only one defender may mark the same non-ball player in the Marking Area.

A defender who is marking an unmarked opponent standing '**directly behind the Goal Circle**' is also exempt from the 3-Seconds Rule, but she is not exempt from the Free Space to Goal Rule. Nor may she remain in the 11m Area for more than 3-seconds when one of her teammates moves behind goal to directly mark the attack player. (Definitions, Rule 23 & Diagram #8)

## 20. MAJOR FOUL RULES & PENALTIES (continued)

A defence player who is inside the Marking Area because she is legally marking an unmarked opponent who is directly behind goal cannot be penalized for the 3-Seconds Rule when drawn into a double-team in front of goal by other attack non-ball players.

The 3-Seconds Rule takes effect when the team in possession of the ball crosses the ball over the Restraining Line into their attacking end of the field. When the defence is called for a 3-seconds violation and

- a. the attack player in possession of the ball is above the goal line extended, the Free Position will be set relative to the spot of the ball when the whistle sounds to stop play.
  - b. the attack ball carrier is below the level of the goal line extended, the Free Position will be set at the nearest 11m mark on the goal line extended.
12. A player must not detain an opponent at any time by holding, tagging, pressing or pushing against an opponent's body, clothing or Crosse with her arm, leg, body or Crosse. A player must not hold an opponent's Crosse after a check to the extent that the opponent's balance or movement is impeded. (See Rule 19.A.18 for the Minor Foul "Hold")
  13. A player must not trip an opponent, deliberately or otherwise.
  14. A player must not set a moving or stationary pick or screen that cannot be seen by the opponent, does not allow enough time and/or space for the opponent to stop or change direction, and contact occurs.
  15. A player must not **Swipe** at her opponent. In addition to awarding the appropriate penalty, a Yellow Card **MUST** be given.
  16. The Goalkeeper, while fully outside the Goal Circle, must not blatantly or purposely play the ball with any part of her body. (Rule 20.B.4)
  17. An unprotected field player/Deputy may not illegally remain in the Goal Circle. (Rule 17.A.4 & Rule 17.C.1.b)
  18. A player or any other Team/Bench Personnel must not act in an unsporting manner or display any other inappropriate behavior. (Rule 22)
  19. A player must not use her Crosse and/or body with force in a dangerous or intimidating manner, and/or show disregard for her own or an opponent's safety. This ruling applies to all players regardless of whether or not they have possession of the ball.

### B. Major Foul Free Positions (Rule 16.B)

1. For Major fouls that occur anywhere on the field **outside the 11m Area, including below the level of the Goal line extended** (no Advantage Flag/Scoring Play), the Free Position is awarded at the spot of the foul, but never closer than 11m to the centre of the Goal Line or within 4m of the boundary. The offender shall stand 4m directly behind the player taking the Free Position. If the Goalkeeper is outside the Goal Circle, she must stand for the Free Position; she may not return to the Goal Circle.
2. When a Major Foul by the defence occurs **within 11m outside the Marking Area (in the "Pie" shaped area)**, the Free Position is set on the nearest hash marking in line with the foul. Only the **Penalty Lane** shall be cleared. (Definitions Rule 23: Diagram #11)
  - a. If the Goalkeeper is outside the Goal Circle and has not fouled, the Goalkeeper must return to the Goal Circle for the Free Position.
3. When a Major Foul by the defence occurs **within the Marking Area**, the Free Position is set on the hash mark inside the Marking Area that is nearest to and in line with the foul. **All players must clear their bodies and Crosses from inside the Marking Area**; the Penalty Lane, will also be cleared, when necessary.
  - a. If the Goalkeeper is outside her Goal Circle and has not fouled, the Goalkeeper must return to the Goal Circle for the Free Position.
4. If the foul prevented an almost certain Goal, the Umpire may move any player(s) positioned between the Free Position and the Goal, including the Goalkeeper. (Rule 20.A.10, 20.A.11, 20.A.16; & 20.A.19)
5. If any defender is in the Free Space to Goal when a Free Position is set, she must not be penalized for blocking the Free Space to Goal unless she does not **immediately** move out of this space when the Umpire blows the whistle to restart play. (Rule 20.A.10)
6. When a Major Foul by the attack occurs **within the 11m Area**, the Free Position will be taken by the defender who was fouled at a spot in line with the foul that is 11m from the centre of the Goal Line. The attack player who fouled moves 4m behind.

## 21. ADVANTAGE FLAG

- A. The Advantage Flag is a Held Whistle for a Major Foul by the defence when the attacking team is on a **Scoring Play** within 15m of Goal. The Advantage Flag Area includes the 15m Fan and the playing area behind the Goal that runs 9m deep and 15m to each side of the centre of the Goal Line. (Definitions, Rule 23, Diagram #7)
- B. The Umpire shall raise a Yellow Flag when an attack player with or without the ball is fouled while her team is on a Scoring Play.
- C. The Scoring Play is over when:
1. a shot is taken.
  2. the attacking team passes or carries the ball behind the level of the Goal Line and fails to continue the initial momentum to score a Goal.
  3. the attacking team stops its continuous effort to complete a shot on Goal, or the defence forces the player with the ball to lose her forward momentum.
  4. the attacking team fouls.
  5. The defence commits another Major or Minor Foul that requires the game to be stopped.
  6. the attacking team loses possession of the ball.
  7. The Umpire must stop the Scoring Play **immediately** for an Obstruction of the Free Space to Goal violation, or for an illegal Deputy in the Goal Circle. While the Yellow Flag is raised, the Umpire may also stop the Scoring Play at any time to prevent injury.
- D. Following the Advantage Flag:
1. if a shot on Goal is successful, the Goal counts.
  2. if the attacking team chooses to shoot, the "advantage" indicated by the Flag is complete/finished, the Umpire lowers the Flag and play continues.
  3. If the Scoring Play ends without a further foul or a shot on Goal, a Free Position shall be awarded to the attack player who was fouled. The defender who committed the foul shall move 4m directly behind. If the foul occurred:
    - a. **between 11m-15m in front of Goal**, the Free Position is awarded where the foul occurred.
    - b. **within 11m outside the Marking Area** (in the 'Pie' shaped area), the Free Position is set on the nearest hash mark. Only the Penalty Lane shall be cleared.
    - c. **within the Marking Area**, the Free Position is set on the nearest hash mark inside the Marking Area. The Marking Area and, when necessary, the Penalty Lane must be cleared.
    - d. **below the level of the Goal Line**, the Free Position is set on the nearest 11m mark on the Goal Line extended. Players shall clear a Penalty Lane above the Goal Line. (Diagram #2, points H and Rule 23, Diagram #10)
  4. If the defence commits subsequent/additional Major or Minor Foul/s anywhere inside or outside the Marking Area that ends the Scoring Play, the Free position is set on the 11m hash mark inside the Marking Area that is nearest to the most recent foul. The defender who fouled shall move 4m behind. The Marking Area and, when necessary, the Penalty Lane will be cleared.
  5. If the defence commits a foul that must be carded when the Scoring Play ends, to resume play, the attack shall be awarded a Major Foul Free Position. (Rule 22.B.3.)
    - a. If the Goalkeeper has saved a shot on goal, the attack Free Position will be awarded at the nearest 11m mark on the goal line extended.
    - b. If a goal was scored, the Free Position will be awarded at the centerline.
    - c. If a defender wins possession of the ball inside the field of play, the umpire will stop play immediately and the Free Position will be awarded at or near the spot of the ball in accordance with the conditions in Rule 20.B.
    - d. If the shot goes out-of-bounds, the Major foul Free Position will be awarded where the ball went out at least 11m from the center of the Goal Line and 4m inside the boundary.
  6. If the attacking team commits any Major or Minor Foul, a Throw will be taken beyond 15m and level with the Goal Line extended. (Diagram #2, beyond points E)
  7. The Goalkeeper shall return to the Goal Circle for a Free Position if:
    - a. she has moved outside the Goal Circle and makes an interception or other legal play that ends the Scoring Play.
    - b. she has moved outside the Goal Circle and is fouled by an attack player, which ends the Scoring Play.
    - c. the Goalkeeper is outside the Goal Circle, has not fouled, and the free position is set **within the 11m Area** (Rule 20.B.2; Rule 20.B.3)

## 22. WARNING CARDS, MISCONDUCT, SUSPENSIONS

### A. Personal Misconduct Fouls

1. A player must not:
  - a. conduct herself in a rough, dangerous or unsporting manner.
  - b. persistently cause infringement of the rules.
  - c. deliberately endanger the safety of an opponent.
  - d. exhibit any type of behavior which in the Umpire's opinion amounts to misconduct.

### B. Penalties for Personal Misconduct Cards (Rule 11.B)

1. Time-out shall be taken to issue all warning cards whenever a warning card is shown it shall be considered a warning to all players.
2. Misconduct and/or Suspensions shall be penalized as Major Fouls.
3. In addition to awarding the appropriate penalty, the Umpire may give verbal or visual cautions as appropriate, or signal Time-out to award the offending player a Yellow Card, a Yellow and Red Card together or a straight Red Card.
4. A player receiving a Yellow Card must leave the field for 2-minutes lapsed playing time. A substitute may take her place. If the player re-enters the game before the timed 2-minutes expires, the player must reserve the entire penalty and remain off the field for an additional 2 minutes.
  - a. If the Yellow Card is her team's third, the player awarded the card must leave the field for 2- minutes lapsed playing time, a substitute may not take her place, and her team must play with one less player below/goal side of the restraining line for the duration of the 2-minute suspension penalty. NOTE: Lapse timed penalties for a straight Red Card or any combination Red/Yellow or Red/Green Cards will override the 2-minute penalty for any Yellow Card. (Rule 11.B.2. & Rule 22.B.5)
  - b. If a Goalkeeper receives a Yellow Card and her team does not have a **'second dressed'** Goalkeeper, the Goalkeeper may remain in the game. For the Free Position, the Goalkeeper shall move 4m behind the attack player awarded the ball. The Goal Circle shall remain empty. If the Yellow Card is the team's third, the player below/goal side of the restraining line and nearest to her team's substitution area must leave the field to begin the 2-minute suspension penalty.
  - c. If the player or a substitute re/enters the game before the timed 2-minute penalty suspension expires, she is an illegal substitute. The player must leave the field to reserve the entire penalty and her team must play short for an additional 2-minutes.
5. A player receiving a second Yellow Card shall be shown a Yellow and Red Card together and shall be suspended from further participation in the game. There must be a 5-minute lapse of playing time before a substitute may enter the game. A player receiving a straight Red Card shall be suspended from further participation in the game, and there must be a 10-minute lapse of playing time before a substitute may enter the game.
  - a. When a player receives a Yellow and Red Card together or a straight Red Card, her team must play with one less player below/goal side of the Restraining Lines for the duration of the timed penalty suspension.
  - b. When a Goalkeeper is suspended from further participation in the game, and her team has a **'second dressed'**, she will replace the suspended Goalkeeper. If the suspended Goalkeeper is her team's **'only dressed'** Goalkeeper, a 2-minute time-out shall be taken to enable the nominated player to put on protective equipment. If this player is on the field a substitute will take her place.
    - 1) To resume play, the Field Player below/goal side of the restraining line and nearest to the substitution area must leave the field to begin the 5 or 10-minute suspension. The replacement Goalkeeper shall stand 4m behind the attack player awarded the Free Position. The Goal Circle shall remain empty.
    - 2) Once play resumes, any eligible player may substitute as long as her team plays short for the duration of the 5 or 10-minute penalty. If a substitute enters the game before the 5 or 10-minute timed penalty suspension expires, she is an illegal substitute and her team must reserve the entire penalty and play short for an additional 5 or 10-minutes.
6. Whenever a player is suspended with less than 2 minutes (Yellow Card), less than 5 minutes (Yellow/Red Card), or less than 10 minutes (straight Red Card) remaining in the half, the timed penalty suspension shall carry over into the second half or overtime, when played.
7. Without any previous warning, an Umpire may suspend a player, coach or other Team/Bench Personnel from further participation in the game if they are guilty of flagrant or repeated violations of the rules, continued dissent, misconduct or abusive language. The suspended person may be requested to leave the field and/or the entire playing area. The game shall be restarted within 30 seconds with a Free Position for the opponent nearest the ball when play was stopped or at the spot where play was to resume before the card was given.
  - a. If the offender refuses to leave the field and/or playing area when requested by the Umpire, her team must forfeit the game.

## 22. WARNING CARDS, MISCONDUCT, SUSPENSIONS (continued)

- b. If the forfeiting team is behind in score, the score shall stand. If the forfeiting team is ahead, the score shall be 1– 0 in favor of the opponents.
- C. Delay of Game and other Persistent Minor Fouls
1. Delay of Game Fouls include:
    - a. failure to “Stand” when the whistle is blown, i.e., creeping;
    - b. failure to move 4m away on a Free Position
    - c. failure to follow an Umpire’s directions or
    - d. any other type of behavior which, in the Umpires’ opinion, amounts to delay.
  2. Persistent Minor Fouls include:
    - a. repeated false start violations (Rule 19.A.19);
    - b. repeated Restraining Line violation (Rule 18);
    - c. teams that repeatedly waste time returning to centre Draw following a goal (Rule 19.A.10);
    - d. any other Minor Fouls that in an Umpire’s opinion occur repeatedly due to lack of skill, or to gain an unfair advantage.
- D. Penalties for Delay of Game and other Persistent Minor Fouls
1. The first time the Umpire awards a card for a Delay of Game/Persistent Minor Foul, the Umpire will show the team’s Captain a Green Card, and if applicable, award the appropriate Minor Foul penalty.
  2. For the second Delay of Game/Persistent Minor Foul penalty, the Umpire will show a Green and Yellow card together to the offending player and award the appropriate Major Foul penalty. The offending player may remain in the game.
  3. For the third and subsequent Delay of Game/Persistent Minor Foul penalties, the Umpire will show the offender a Green and Red Card together and award the appropriate Major Foul penalty. The suspended player or a substitute may enter the game after a 5-minute lapse of playing time has expired.
    - a. When a player receives a Green and Red Card together, for the duration of the 5-minute time lapsed penalty suspension, her team must play short below/goal side of the Restraining Lines.
    - b. Whenever a player is suspended for delaying the game with less than 5 minutes remaining in the half, the suspension will carry over to the second half or overtime, when played.
    - c. If the suspended player or her substitute enters the game before the 5-minute suspension expires, she is an illegal substitute and must leave the field. The player must re-serve the entire suspension and her team must play short for an additional 5 minutes.
    - d. Delay of Game and other Persistent Minor Fouls need not be identical.
- E. The warning card procedures for Personal Misconduct Fouls and those for Delay of Game and other persistent Minor Fouls operate independent of one another. Therefore, it is possible for a player to receive a Yellow Card and then receive a Yellow/Green Card.
- F. At any time during the game, at an Umpire’s discretion and without previous warning, an Umpire may award a Misconduct Personal Foul warning card for any Delay of Game or other persistent Minor Foul that is committed in a dangerous or unsporting manner.

## 23. DEFINITIONS

**Advantage Flag:** A Held Whistle for a Major Foul by the defence when an attack player, with or without the ball, is on a Scoring Play within 15m of Goal. The Umpire raises a Yellow Flag and verbally calls "Flag". (Rule 21)

**Blocking:** A player moves into the path of an opponent with the ball without giving that player sufficient time to stop or change direction and causes contact. When a player is running to receive the ball a "**blindside**" (unsighted defender) must give her enough time and/or space to stop or change her direction. (Rule 20.A.6)

**Body Checking:** A technique whereby a defender moves with an opponent without body contact occurring. The defender mirrors each movement of the opponent's body and Crosse with her own body thereby causing her opponent to slow down, change direction or pass the ball.

**Charging:** The player with the ball, pushes into, shoulders, or backs into and makes bodily contact with her opponent who has already established her legal defensive position, though not necessarily stationary. (Rule 20.A.6)

**Clear:** Any action taken by a player who is legally within the Goal Circle to pass or carry the ball out of the Goal Circle.

**Clear Space** indicates the space between players which is free of Crosses or any parts of another player's body.

**Creeping:** Illegal movement by a Field Player after a whistle is blown to stop play when players are required to Stand.

**Crosse Checking:** An extension of body checking whereby the defender attempts to dislodge the ball from an opponent's Crosse by using controlled Crosse-to-Crosse contact.

**Deputy:** An unprotected Field Player on the defensive Goalkeeper's team who may enter or remain in the Goal Circle only when her team is in possession of the ball and the Goalkeeper is out of the Goal Circle. (Rule 17.A.3)

**Directly Behind the Goal:** The area between two imaginary lines extending perpendicular and back from the Goal Line extended and tangent to the Goal Circle. (Rule 20.A.11)

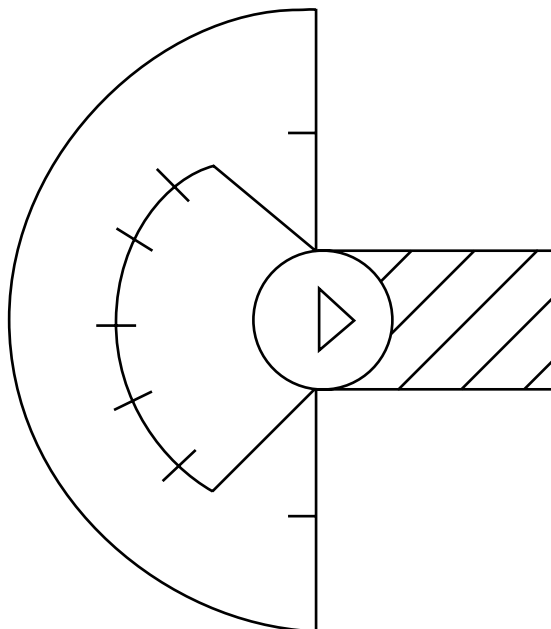

**Diagram #8**  
**Directly Behind the Goal Circle**  
**Rule 20.A.11**

**23. DEFINITIONS** (continued)

**Free Space to Goal:** An imaginary path to Goal as defined by two lines extending from the ball, which must be within 15m of Goal, to the outside edges of the Goal Circle. No defender will be penalized if positioned below the extension of the Goal Line, as shown. (Rule 20.A.10)

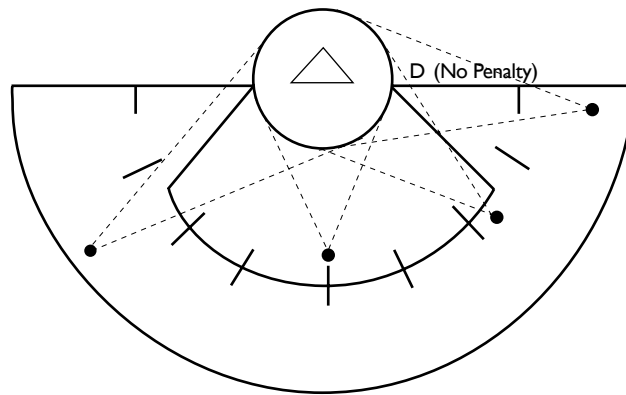

**Diagram #9**  
**Free Space to Goal**  
**Rule 20.A.10**

**Grounded** refers to any part of the Goalkeeper's (or the Deputy's) body touching the ground for support and completely outside the Goal Circle Line while attempting to play the ball from inside the Goal Circle. (Rule 17.a.3.d)

**Held Whistle:** (Rule 16.C)

**In Possession of the Ball:** A player has the ball in her Crosse, and she can perform any of the normal function of control such as cradling, carrying, passing or shooting the ball. (Rule 14.B.1)

**Penalty Lane:** The path to Goal defined by two imaginary lines that extend the width of the Goal Circle to 4m either side of the ball carrier. All other players must clear their bodies and Crosses from this space when certain Free Positions for Major Fouls are awarded within 11m in front of Goal.

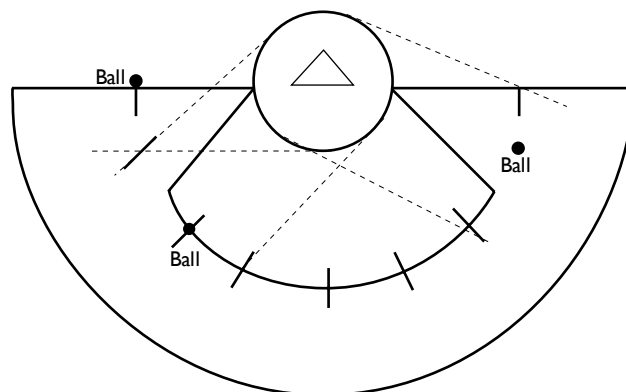

**Diagram #10**  
**Penalty lane**  
**Rule 20.B.2**

## 23. DEFINITIONS (continued)

**Pick:** An offensive technique by which a player without the ball uses her positioning to force an opponent to take another route. To be legal, moving or stationary picks must be set within the Visual Field of the opponent. The opponent must be given enough time and space to stop and/or change direction. (Rule 20.A.14)

**Played** refers to an action whereby the ball leaves the player's Crosse and is touched by another player, or her Crosse is checked Crosse to Crosse by an opposing player.

**Scoring Play** is a continuous effort by the attacking team to move the ball toward the Goal and to complete a shot on Goal. (Rule 21.A)

**Scoring Play Ends:** See Advantage Flag, Rule 21.C.

**Shot:** Propel the ball in the direction of the Goal with the intent to score a Goal.

**Swiping:** Swinging the Crosse at an opponent's Crosse or body with deliberate viciousness or recklessness, whether or not the opponent's Crosse or body is struck. (Rule 20.A.14)

**Team / Bench Personnel:** Includes the coach, assistant coaches, manager, medical staff and players. (Rule 1.J and Rule 22.B.6)

**Team Substitution Area:** The space defined by two markers placed 4m apart and even with the Scorer's/Timer's table extended. Players waiting to substitute must stand behind the markers. (Rule 1.J)

**Toeing the Centerline:** Refers to the placement of the foot during the Draw, up to, but not on, the centreline. (Rule 12)

**Visual Field** is a player's peripheral vision. A player is responsible for using her peripheral vision to see her opponent/s. A player's peripheral vision is 180 degrees using a player's nose as the point of reference, not her shoulders. (Rule 20.A.6 and Rule 20.A.14)

**Within a Stick's Length** is INSIDE a Crosse's length and arm's length extended (approximately 1.5m). It is the maximum distance a player may be from her opponent and be considered **legally or actively marking** this opponent. (Rules 20.A.10 and 20.A.11)

## 24. TOURNAMENT RULES

- A. For IFWLA events, a roster of eighteen (18) players constitutes a full team. Six (6) support staff are allowed in the Team/Bench Area during games. (Rule 5.A.)
- B. The colour of the ball shall be solid Yellow.
- C. The Scorekeeper will record the time of goals and any other necessary game statistics.
- D. If one team is leading by twelve (12) or more goals, the clock shall continue to run after a goal is scored. (Rule 12)
- E. In Tournament Play, when there is a tie on points, it is recommended that the Goal Differential Formula will be applied:

$$\frac{\text{Goals For} - \text{Goals Against}}{\text{Total Goals}}$$

In the formula, the scores of all the games in the Round Robin of the tied teams are used. The maximum difference in scores allowed per team will be twelve (12), which is achieved by reducing "Goals For".

Actual scores are used except those matches in which the Goal differential exceeds 12. In these cases, the Goal difference is reduced to 12. For example, a score of 15 – 1 will be reduced to 13 – 1 before using the Goal formula.

## 24. TOURNAMENT RULES (continued)

- F. Overtime Procedures – Playing off a tie game when required.
1. When the score is tied at the end of regulation playing time, both teams will have 5 minutes rest and toss the coin for choice of ends. The lower seeded team or the team dressed in the dark shirts shall call the coin toss for choice of end to defend.
  2. A full six (6) minutes of stop-clock overtime shall be played in sets of two 3-minute periods. At the end of the first 3-minute period, the teams shall change ends with no delay for coaching. The game will be restarted with a centre Draw. The team that is ahead at the end of the full six minutes wins the game.
  3. When a team has not used its two Team Time-outs during regulation, they may request a Time-out/s in overtime play.
  4. If the teams are still tied after the full six minutes of overtime, they shall have three minutes of rest and change ends.
  5. The winner will then be decided in a “Sudden Victory” stop-clock overtime of not more than six minutes. If a winning Goal is not scored in the first 3-minute period, teams shall change ends with no delay for coaching. The game shall be restarted with a centre Draw. The team scoring the first Goal wins the game.
  6. Play will continue with “Sudden Victory” stop-clock overtime periods of 6 minutes in length. Teams will continue to change ends after each 3 minutes of play. Teams will have 3 minutes of rest between every 6-minute period until a winning Goal is scored.
- G. Any Player who receives one straight Red Card or two combination Yellow/Red Cards for Personal Fouls shall be suspended from the next match within the Tournament.
- H. Uniform advertising: A maximum of 3 advertisement emblems/logos may be worn on the player’s field uniform or body. Advertisement emblems/logos must not exceed 40 square centimeters.
- I. Uniform Shirts:  
1<sup>st</sup> Strip/Uniform (Home Team) – Light coloured shirt.  
2<sup>nd</sup> Strip/Uniform (Away Team) – Dark coloured shirt.  
Teams shall have two alternate blood shirts in each colour.
- For IFWLA Tournaments, numbers **1-40** only are permitted on team shirts. **Numbers at least 15cm** tall must be centred on the front of the shirt, and **numbers at least 20cm tall** must be centered on the back of the shirt. Playing numbers must be written in **plain block font** and the colour of the numbers must clearly contrast the colour of the shirts. If a team wears a patterned shirt, the numbers must be superimposed on a solid, clearly contrasting colour block background. **(Required for the 2009 World Cup)**
- J. Technical Delegates shall set Tournament and Bench Rules in accordance with IFWLA Rules Book Rule 1.J and IFWLA World Event Guidelines Appendix D.

## 25. MANUFACTURER’S SPECIFICATIONS

- A. All Field Crosses
- The primary intent of the Field Crosse specifications is to ensure that the ball moves freely within all parts of the head and pocket so that the ball may be dislodged from a Crosse without an excessively forceful check.
- A Crosse may be deemed illegal even though it meets all technical specifications, if in the opinion of the IFWLA, its design is an obvious attempt to circumvent the intent of the rules.
- A Crosse that has been altered in such a way as to give an unfair advantage to a player is illegal.
1. The head of the field Crosse shall be constructed of wood, plastic, fiberglass, nylon, leather, rubber, gut, and/or any other synthetic material.
  2. The handle of the Crosse shall be straight and may be constructed of wood, metal alloy or other composite material.
    - a. Recessed metal screws with round heads shall be used to attach the head of a plastic/molded head Crosse to the handle. The butt ends of all handles shall have an end cap, be taped or sanded smooth, if wood.
    - b. The Crosse shall not have sharp or protruding parts or edges and shall not be dangerous to players in any way.
  3. The over all length of the Crosse shall be 0.9m /90cm minimum to 1.1m /110 cm maximum. End caps are included when measuring the overall length of a Crosse.
    - a. To determine compliance with the line measurement specifications in Rule 25, all measurements shall be made to the nearest 0.01cm. The allowed deviation from the standard is 0.09cm.

## 25. MANUFACTURER'S SPECIFICATIONS (continued)

4. The unstrung head and the handle of a field Crosse shall lie within a 5.1cm horizontal plane. (Diagram #11)
    - a. At the Bridge or the Ball Stop, the top edge of the Bridge or Ball Stop must be at least 1.3cm above the centerline of the handle.
    - b. The top edge of the sidewall must not be more than 0.6cm below the center line of the handle
    - c. The top edge of the sidewall must not drop below the centerline of the handle prior to 5.7cm as measured from the centre of the Bridge or Ball Stop.
  5. The overall length of the head, as measured from the centre of the Bridge or Ball stop (where the top, back edge of the stop pad meets the plastic) to the top outside edge of the scoop, shall be 25.4cm minimum to 30.5cm maximum. With the open pocket facing up, all length measurements are taken along the centerline of the handle.
  6. The overall outside width of the head of the Crosse when measured at the widest point at the top of the head must be 18cm minimum to 23cm maximum. With the open pocket of the head facing up, all width measurements are taken on a line that is perpendicular to the extension of the handle.
  7. Sidewall stringing holes: From the bottom of the sidewall to the bottom of the stringing hole shall be no more than 1.0cm.
  8. The entire Crosse (strung head and handle) shall not weigh more than 567 g.
- B. The Wooden Field Crosse
1. The head of a Wooden Field Crosse is defined to consist of four parts: The Bridge, the Wooden Sidewall, the Guard and the Scoop. (Diagram #12)
    - a. The Bridge is the woven ball stop of a wooden Crosse. The height of the Bridge shall be 5.1cm maximum to 3.2cm minimum.
    - b. As measured from the centre of the Bridge to the midpoint of the head, the actual height of the wooden sidewall shall be 4.5cm maximum to 3.2cm. From the midpoint of the head, the height of the sidewall may taper toward the scoop.
    - c. The Guard is the soft woven wall of the head. The height of the Guard shall be 7cm maximum to 3.2cm minimum.
  2. The head shall be triangular in shape. The inside width between the sidewalls of the head must continually increase as measured from the centre of the Bridge to the widest point at the top of the head.
    - a. The inside width between the sidewalls of the head, as measured 3.2cm from the centre of the Bridge, shall be 6.7cm to 7.6cm, and the outside width of the head shall be 7.6cm to 10.1cm.
    - b. The inside width between the sidewalls of the head, as measured 5.1cm from the centre of the Bridge, shall be 7cm minimum.
    - c. The inside width between the sidewalls of the head, as measured 7.6cm from the centre of the Bridge, shall be 8cm minimum.
    - d. The inside width between the sidewalls of the head, as measured 10.2cm from the centre of the Bridge, shall be 9cm minimum.
    - e. The inside width between the walls at the widest point at the top of the head shall be 15cm to 16cm.
- C. Plastic/Molded Head Crosse (Diagram #14)
1. The head of the Plastic/Molded Head Field Crosse is defined to consist of four regions: the Throat, the Ball Stop, the Sidewall and the Scoop. (Diagram #12)
    - a. The Ball Stop is the centre inside curved plastic wall of the head at the throat. The wall of the Ball Stop must not deviate by more than 5 degrees from perpendicular to the long axis of the handle. To determine Crosse compliance with angular measurement specifications in Rule 25 all measurements and calculations will be made to the nearest 0.01°. The allowed deviation from the standard is 0.44°
      - 1) The height of the Ball Stop shall be 5.1cm maximum to 3.2cm minimum.
      - 2) Stop pads shall not be more than 0.5cm thick. With the open pocket of the head facing up, the stop pad shall not vary in thickness from the top to bottom of the Ball Stop. The stop pad must cover at least 60% of the Ball Stop, top to bottom. The overall length of the stop pad shall be 9.5cm maximum. The surface of the stop pad may not be textured, raised, recessed or in any way interfere with the free movement of the ball in the pocket.
    - b. The stop area ends and the sidewall begins as measured 3.4 cm from the centre of the Ball Stop. The sidewall ends and the scoop area begins at the widest point at the top of the head. (Rule 25.C.2.e)
      - 1) From the beginning of the sidewall at 3.4cm to the midpoint of the head, as measured from the centre of the Ball Stop to the top of the scoop, the actual height of the sidewall shall be 4.5 cm maximum to 2.8cm minimum. From the midpoint of the head the height of the sidewall may taper toward the Scoop.

## 25. MANUFACTURER'S SPECIFICATIONS (continued)

- 2) There may be no protrusions or outcroppings on the inside surface of the sidewalls. The sidewalls may not be lined with any additional material
  2. The head of the Crosse shall be triangular in concept. The inside width between the sidewalls of the head must continually increase as measured from the centre of the Ball Stop to the widest point at the top of the head. (Diagram # 13)
    - a. The inside width between the sidewalls of the head, as measured 3.2cm from the centre of Ball Stop, shall be 6.7cm to 8.0cm maximum. The radius of the ball is 3.2cm.
    - b. The inside width between the sidewalls of the head, as measured 5.1cm from the centre of the Ball Stop shall be 7cm minimum.
    - c. The inside width between the sidewalls of the head, as measured 7.6cm from the centre of the Ball Stop, shall be 8cm minimum.
    - d. The inside width between the sidewalls of the head, as measured 10.2cm from the centre of the Ball Stop shall be 9cm minimum.
    - e. The inside width between the walls at the widest point at the top of the head, shall be 16cm minimum.
  3. At all points along the sidewall, the following formula shall be used to determine the maximum slant/angle the sidewalls may deviate from vertical. (Diagram #15)
    - a. With the open pocket of the head facing up, measure the vertical height of the sidewall at any point. Find the difference in the width between the top and bottom edges of the sidewall at that point.
    - b. At all points, the difference between the top and bottom widths divided by the vertical height of the sidewall, must be less than or equal to 0.05.
- D. The pockets of all Wooden or Plastic/Molded Field Crosses:
1. The pocket of all field Crosses shall be strung with 4 or 5 longitudinal leather or synthetic thongs and 8 to 12 stitches of cross lacing. MESH POCKETS ARE NOT ALLOWED.
    - a. Longitudinal leather or synthetic thongs shall be 0.6cm to 1.0cm wide. Thongs must not touch, and 'nominally', must be evenly spaced along the length / across the width of the head. Loose ends of thongs may not be woven back up through the pocket of the Crosse and during play must be secured to the handle of the Crosse. (Diagram #12)
    - b. Cross-lacing in a traditionally strung pocket is defined as 8-12 knots/stitches, where two strings intertwine as a common place on a thong and evenly spaced (not bunched) diamonds. (A 'diamond' is the shape formed between two longitudinal knots on thongs and two horizontal knots).
    - c. Cross-lacing in a pre-manufactured detachable pocket is defined as 8-12 evenly spaced pocket nylon laces that are sewn or traditionally woven between evenly spaced longitudinal thongs. (Rule 25.D.1.a) Extra lengths of sidewall nylon ties must be cut to 4 cm maximum.
    - d. The nominal diameter of the shooting/throw string and sidewall nylon cord shall be 0.3cm maximum. The nominal diameter of pocket nylon must be less than 0.3cm.
      - 1) Field Crosses shall have no more than two separate shooting/throw strings. Shooting/throw strings shall not be rolled more than twice between each thong. Flat hockey or boot laces may not be used as shooting/throw strings.
      - 2) Both shooting/throw strings must be attached in the upper third of the head, or the top shooting/throw string must be attached in the upper third of the head, and the bottom shooting/throw string may be an "inverted U" in shape and must be attached in the upper one-half of the head, as measured from the top, outside edge of the scoop. (Diagram #16)
  2. The combined height of the sidewall and the depth of the pocket containing the ball must be less than 6.4cm, the diameter of the ball. The top of the ball, when dropped into the pocket of a horizontally held Crosse, must be visible and remain above the top of the entire wooden or plastic sidewall after reasonable force with one hand has been applied to and released from a ball.
  3. The ball must move freely within all parts of the head/pocket both laterally and along its full length.
    - a. The ball must not become wedged between the walls, under the Guard or the Bridge of a Wooden Crosse or in the Ball Stop or under the walls of a Plastic/Molded Head Crosse. The ball must easily fall out of the pocket of the Crosse when the Crosse is turned upside down.
  4. At any time during play, an Umpire may take time-out to inspect a field Crosse, or any player on the field may request that an Umpire inspect an opponent's Crosse. If the ball becomes lodged in a Field Player's Crosse during play, the Crosse no longer meets specifications. The umpire shall take time-out to remove the illegal Crosse to the Scorer's/Timer's table. To resume play, the opponent nearest to the ball shall be awarded a Free Position for a Minor Foul. (Rule 19.A.12, Rule 19.A.13, and Rule 19.A.14)

## 25. MANUFACTURER'S SPECIFICATIONS (continued)

- E. The Goalkeeper's Crosse
1. The Crosse shall be constructed of wood, plastic, fiberglass, nylon, leather, rubber, gut, and/or any other synthetic material.
  2. The handle of the Crosse shall be straight and may be constructed of wood, metal alloy or other composite material.
    - a. Recessed metal screws must be used to attach the head to the handle. The butt end of the handle shall have an end cap, be taped or sanded smooth, if wood.
    - b. The Crosse shall not have sharp or protruding parts or edges and shall not be dangerous to players in any way.
  3. The overall length of the Crosse shall be .9m /90cm minimum to 1.35m/135cm maximum.
    - a. To determine compliance, with linear measurement specifications, all measurements shall be made to the nearest 0.01cm. The allowed deviation from the standard is 0.09cm (Rule 25.A.3.a.)
  4. The unstrung head and the handle of a Field Crosse shall lie within a 7.6cm horizontal plane. (See Rule 25.A.4 Guidance to determine the horizontal plane.)
    - a. No part of the head shall pass beyond a plane 2.5cm above the centreline of the handle and/or 5.1cm below the centreline of the handle.
    - b. The top edge of the sidewall shall not be more than 0.6cm below the centreline of the handle.
  5. The head shall have a maximum length of 42 cm. The length of the head is measured from the centre of the Bridge or Ball Stop (where the back top edge of the stop pad meets the plastic) to the top outside edge of the scoop. With the open pocket of the head facing up, all length measurements are taken along the centreline of the handle.
  6. The height of the Bridge or Ball Stop of a Goalkeeper's Crosse shall be 5.4 cm maximum to 3.2cm minimum. The plastic wall of the Ball Stop must not deviate by more than 10 degrees from perpendicular to the long axis of the handle. (Rule 25.C.1.a)
  7. The sidewall begins as measured 3.4cm from the center of the Bridge or the Ball Stop. The actual height of the wooden sidewall of a wooden Crosse and the plastic sidewalls of a molded head Crosse shall be 5.1cm maximum to 2.54cm minimum. The sidewall ends at the widest point at the top of the head. The height of the woven wall of a wooden goalkeeper's Crosse shall be 7cm maximum.
  8. The entire head of the Crosse shall be triangular in concept. The inside width between the sidewalls of the head must continually increase as measured from the centre of the Bridge or the Ball Stop to the widest point at the top of the head. With the open pocket of the head facing up, all width measurements are taken between the plastic or woven and wooden sidewalls on a line that is perpendicular to the centreline of the handle. (See Guidance, Rule 25.C.2.)
    - a. When measured 5.1cm from the centre top edge of the Ball Stop, the inside width between the sidewalls of a plastic/molded head Crosse shall be 13cm to 16.5cm. The maximum outside width of the head shall be 19.5cm.
    - b. When measured 10.2 cm from the centre top edge of the Ball Stop, the inside width between the sidewalls of a plastic/molded head Crosse shall be 18.5cm to 22 cm. The maximum outside width of the head shall be 26cm.
    - c. When measured 15.3 cm from the centre top edge of the Ball Stop the inside width between the sidewalls of a plastic/molded head Crosse shall be 23cm to 26cm. The maximum outside width of the head shall be 30cm.
    - d. At the widest point of the head, the inside width between the walls of the head of the Crosse shall be 28.5cm to 30.5cm. The maximum outside width of the head shall be 33cm.
  9. The pocket of the Crosse may be strung traditionally with 6 or 7 longitudinal leather or synthetic thongs and 8 to 12 stitches of cross-lacing (Rule 25.D.1) or **MAY BE MESH**.
    - a. The Goalkeeper's Crosse may have more than two shooting/throw strings and flat hockey/boot laces may be used as shooting/throw strings. There are no restrictions regarding the design or placement of shooting/throw in the pocket of the Crosse.
  10. The depth of the pocket, containing the ball, may be unlimited except that the ball must move freely within all parts of the head/pocket both laterally and along its full length. When the Crosse with the ball in it is held at eye level with the long axis of the stick vertical to the ground, more than half of the ball must be seen above the Ball Stop.
  11. The Crosse (strung head and handle) shall not weigh more than 773g.

**NOTE:** All IFWLA approved Crosses are evaluated in a laboratory for compliance to written measurement and pocket design standards. The IFWLA shall not be liable for any consequence deriving from the choice of equipment used by players nor any defects it may have. Players shall not alter their equipment to gain advantage.

### F. The Ball (See Rule #4)

### G. The Goal and Goal Netting (See Rule #2 and Diagrams #4 & #5)

Specifications for all equipment are reviewed annually and modified periodically by the IFWLA Rules and Umpiring Committee. The IFWLA will endeavour, when possible, to provide advance notification of changes to equipment specifications to the manufacturers of lacrosse equipment known to the IFWLA. However, the IFWLA reserves the right to change any equipment specifications at any time, if in its sole discretion the IFWLA deems the changes to be in the best interest of the sport of women's lacrosse.

## **ARM SIGNALS FOR UMPIRES**

**BLOCK:** Place open hands on hips and move them to touch hips with an in-and-out motion.

**CHARGE / OFFENSIVE FOUL:** Place the palm of one hand behind head and give direction with the other hand.

**DANGEROUS FOLLOW-THROUGH:** Mimic the follow-through motion with one arm.

**DANGEROUS PROPELLING:** Mimic a two-handed side-arm swing or batting motion.

**DANGEROUS SHOT:** Open palm of one hand and move toward face.

**EMPTY CROSSE CHECK:** Use the right hand with a clapping motion on the left hand.

**HELD CROSSE (Minor Foul):** Clap hands and then hold them together briefly

**FREE POSITION OR POSSESSION OF BALL ON OUT-OF-BOUNDS:** With one arm held horizontally at shoulder height, indicate the direction toward the attacking Goal of the team that will be awarded possession.

**GOAL:** Facing the centre of the field, the Umpire first raises both arms straight above their head and then lowers and points both arms horizontally toward the centre of the field.

**GOAL CIRCLE FOUL:** Point to the Goal Circle line and then indicate direction of the Free Position.

**HELD WHISTLE:** Raise arm horizontally at shoulder level, and in the direction of the fouled player's goal.

**ILLEGAL BODY BALL TO DISTINCT ADVANTAGE:** Indicate by pointing to the part of the body that touched the ball.

**ILLEGAL CHECK ON THE BODY:** Make a chopping motion with one hand on the part of the body where contact was made.

**ILLEGAL CRADLE / PROTECTING THE CROSSE:** Make a cradling motion using one hand pulled in close to the face or body.

**NO GOAL:** With both arms extended toward the ground, swing them in and out so they cross one another, followed by a direction signal.

**OBSTRUCTION OF THE FREE SPACE TO GOAL:** Arms are held in front of the body with finger tips facing up and palms toward face. One hand is closer to the face; hands are in a line, and about 16cm apart.

**PUSHING OR BODY CONTACT:** Make a pushing motion with both arms out in front of body.

**RE-DRAW:** Place arms fully extended horizontally in front of the body. Begin with hands together and extend them up and out with a quick motion.

**RESTRAINING LINE VIOLATION:** One arm raised arm straight up over head.

**ROUGH CHECK:** Use the arm to make a large chopping motion against the wrist of the opposite arm.

**SWIPE:** One arm in a large circular motion close to the head.

**TEN SECOND COUNT FOR BALL IN GOAL CIRCLE:** Extend arm laterally (from the shoulder out to the side) for each second counted.

**THREE SECONDS RULE:** Three fingers raised, palm away.

**TIME-OUT:** Turn toward the Scorer/Timer and cross fully extended arms at wrist above the head.

**TRIP:** Swing hand across the back of the leg at or below the knee.

**THROW:** With both hands in front of the body, fist with thumbs up, move hands up vertically.

**VISUAL ARM SIGNALS FOR UMPIRES**

 <p><b>TIMEOUT</b></p>	 <p><b>SUBSTITUTION</b></p>	 <p><b>TEN SECOND COUNT</b></p>	
 <p><b>HELD WHISTLE</b> <b>FREE POSITION</b></p> <p><b>POSSESSION OF BALL ON OUT-OF-BOUNDS</b></p>	 <p><b>RE-DRAW</b></p> <p><b>GOAL</b></p>		
 <p><b>BLOCKING</b></p>	 <p><b>OFFENSIVE FOUL</b></p>	 <p><b>EMPTY CROSSE CHECK</b> <b>HELD CROSSE</b></p>	 <p><b>ILLEGAL BALL OFF BODY</b></p>
 <p><b>ILLEGAL CHECK ON BODY</b></p>	 <p><b>PUSHING OR BODY CONTACT</b></p>	 <p><b>ROUGH CHECK</b></p>	 <p><b>NO GOAL</b></p>
 <p><b>GOAL CIRCLE FOUL</b></p>	 <p><b>OBSTRUCTION OF FREE SPACE TO GOAL</b></p>	 <p><b>THREE SECOND RULE</b></p>	 <p><b>SWIPE</b></p>

## **APPENDIX A**

### **IFWLA POLICY REGARDING BLOOD ON UNIFORMS, SKIN, EQUIPMENT AND SURFACES**

Whenever a participant suffers a laceration or wound where oozing or bleeding occurs, an official shall stop the game at the earliest appropriate time, and the player or official shall be required to go to the team bench area to receive medical treatment. The participant that has been removed shall not reenter the game without approval of medical personnel.

If there is blood on any part of a player's uniform, skin or other personal equipment, medical personnel should determine whether the blood has saturated the uniform or equipment enough to require a change. A uniform is considered saturated when blood has soaked through the uniform to a player's skin or is capable of being transferred to another player. The same saturation criteria should be applied to a player's personal equipment (stick, gloves, pads, knee brace, etc.) If the uniform shirt is changed the player's new number must be recorded on the team score sheet before the player reenters the game. It is recommended that teams travel with extra uniforms.

Before the game is restarted, appropriate medical personnel must clean to decontaminate any and all surfaces that are contaminated with blood, including the playing field if necessary.

In the event of an injury, time out shall be called at the discretion of the umpire. If in the opinion of the umpire, the injury is serious or the player's safety is compromised in any way, the officials shall suspend play immediately. Otherwise the official may delay the whistle to allow a team to complete a Scoring Play. When time-out is called the umpire will beckon team medical personnel onto the field to attend to the injured player.

If a Field Player is not ready to resume play after 2 minutes recovery time or a goalkeeper is not ready to resume play after 5 minutes recovery time, a substitute must take their place. However, if a player sustains a serious injury, play shall be suspended until the injured player can be safely moved off the field and a substitute has taken her place.